

DBV

DBV VALVE CO.,LTD

Floating

Trunnion

Top Entry

Full Welded

Double Block & Bleed



Petrol-chemical, Natural Gas Pipeline

ONE-STOP CUSTOM VALVE SOLUTION

www.dbv-armaturen.com



DBV Aims To Find Any Reliable Solution With Its Best Service System. All Of DBV Solutions Are With Qualified Materials Which Are Well-Considered On Its Application Areas and Personnel Securities.

Adopting The Updated Equipments, All Of Products From DBV Can Be Endured A Continuous And Precise Inspection . Well-know The Valves System FromAll of Aspects Is The Best Present For All Of DBV Valued Customers .

Choose DBV Means That You Have Selected A Right Area Leading Supplier.



We Are AimingAt SupplyingQuality Products, As An Organization Which Is Grouped By Experts Spaced In Every Where and Every Minute. DBV Experts Give AllTimely Technical Supports And Consultations No Matter On The Assembling , Inspection or Operation .

Only The Inspected And Well-Controlled Products Can be Valued As Quality Products.



Continuously Technical Developments
 Innovation Aims And Technique Advantages
 Agile Solution To Different Cases
 Most Perfect Service System
 Continuously And Meticulous Technical Supports
 Global Marketing Service System

Advanced Schedule System Insurance ,
 Effective Allocations And Requirements
 On Different Products , DBV Organized
 Innovation And Production Based On The
 Market Latest Developments Which
 Effectively Shortened The
 "Feedback" Time.



TYPE	SIZE	ENDS	CLASS
Floating	1/2"~8"	FLGD, THRD, WELD, WAFER	CL150~CL1500, PN10~PN260
Trunnion	1/2"~48"	FLGD, THRD, WELD	CL150~CL2500, PN10~PN420
Top Entry	1/2"~30"	RTJ, RF, B.W	CL150~CL2500, PN10~PN420
Full Weld	1/2"~36"	FLGD, BW	CL150~CL2500, PN10~PN420
Double Block & Bleed	1/2"~24"	FLGD, B.W	CL150~CL2500, PN10~PN420

MAIN PARTS MATERIAL	RANGE DESIGNATION
Body/Cover	Cast/Forged Carbon Steel and Stainless Steel, Cast and Forged Alloy, Specials
Seat+Seal	PTFE/Nylon/PEEK+Viton/Grphite, RTFE+PTFE, Meal+Viton, Special

Today the whole DBV valves design, manufacturing and testing process is covered by a quality assurance program certified and continuously audited by accredited inspection authorities in accordance with ISO9001:2000, Directive 94/9/EC

Strictly Raw Material Inspection Ensuring The Products Max. Security. Strictly Production Procedures Control. Timely and Reliable Report Follows On Each Product Production Procedures and Applications .

DBV Is Not Only Your Qualified Supplier, But Also Can Be Valued As Your Credible Partner Depending On Its Excellent Capabilities And Various Of Production Requirements That Can Be Met.

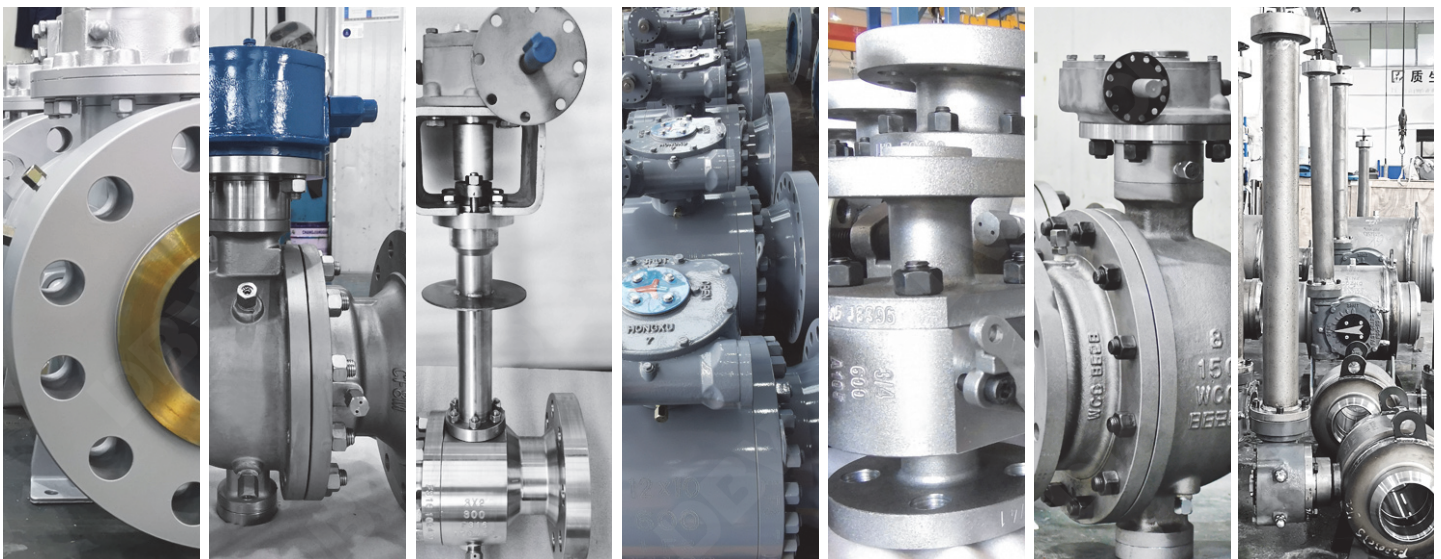

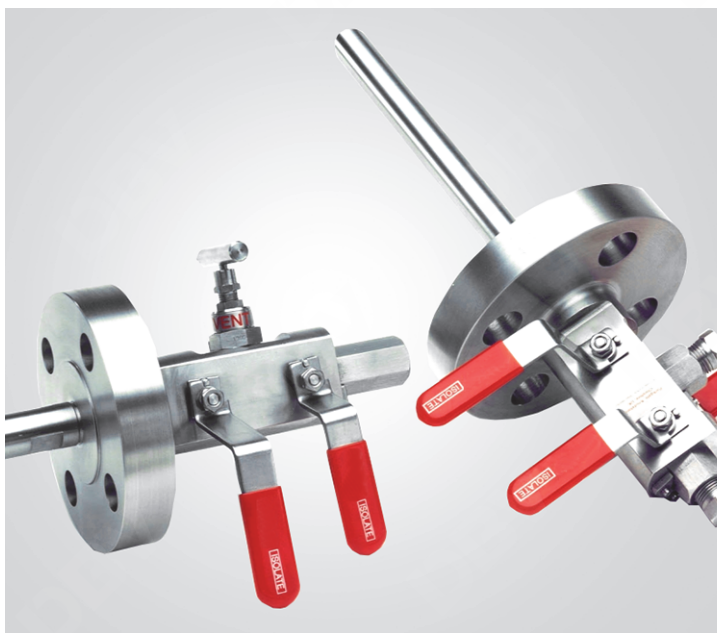
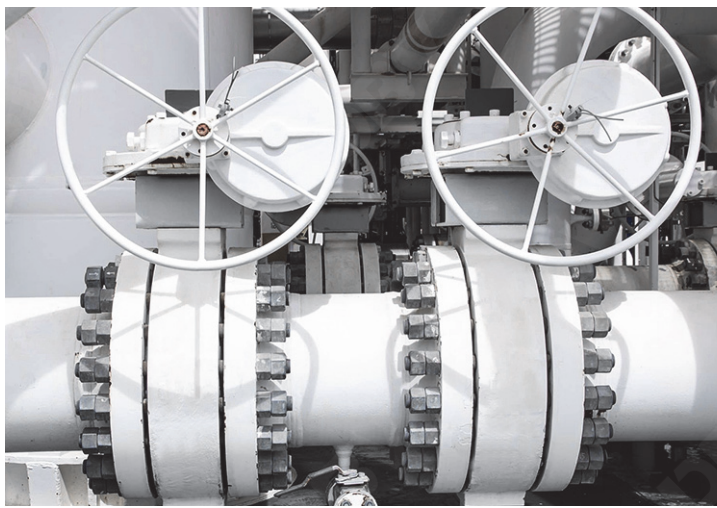



TEST LAB

CRYOGENIC TEST

The cryogenic tests are used to characterize and qualify phenomena and materials in fields of physics dealing with low temperatures, magnets and accelerators which is applied to those items are subjected to the low temperature applications



ULTRASONIC FLAW DETECTORS

Ultrasonic flaw detection is basically a comparative technique for non-destructive tests. A trained operator identifies specific corresponding to the response from good parts and from representative flaws.



POSITIVE MATERIAL IDENTIFICATION (PMI)

The raw materials are verified by sampling with the Qualified Material Analyzer before being released for the machining process to make sure that they comply with the specified chemical properties.

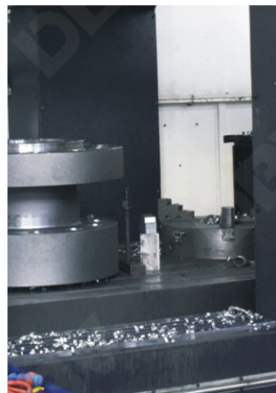

FIRE TESTING

Installation area for valves subject to fire testing under API requirements. The test exposes the valve to a flame temperature of 1400 F to 1800 F (761 to 980) for 30 minutes with controlled limits on leakage.



RADIOGRAPHIC TEST

RT involves gamma- or X-radiation to examine internal features of a test subject. To ensure quality materials are used onto all of fabrications, R.T tests are frequently performed onto DBV manufacturing procedures.



CONTROL AND RECORDING

In addition to a routine inspection of Dimensional Control, Hydra-static and Leakage Tests. A computerized system is used to control the test and to record the results. This provides accurate and permanent documentation.





DBV FLOATING BALL VALVE SERIES

DBV Series Floating Ball Valves are a prime example of reliability, performance, manufacturing and superior engineering techniques at work. Featuring a uni-body or two-piece bolted design.

GENERAL DESIGN FEATURES

- NACE MR0175-(ISO 15156)
(Stainless Steel ball/stem configuration)
- Blowout proof stem
- Weather Seal (Class 600 and higher)
- Actuator mounting pad (4 bolt machined)
- API 6D
- API 607 4th Edition (O-Ring & Graphite)
- Secondary Metal-to-Metal Sealing
- Full rated bi-directional dead end service
- Antistatic Device
- Lockable handle (optional)
- O-Ring design (standard)
- Graphite or Teflon packed (optional)

SIZE RANGE AND DESIGN AVAILABILITY

SIZE (in.)	CLASS/CONFIGURATION				
	150	300	600	900	1500
1FP	●	●		●	●
1-1/2 FP	●	●	●		
2RP	■	■	●	●	
2FP	●	●	●	●	
2-1/2RP	●	●	●		
3 RP	■	■	●		
3 FP	●	●	●		
4 RP	■	■	●		
4 FP	●	●	●		
6 RP	■	■	●		
6 FP	●	●	●		
8 RP	●	●	●		
8 FP	●	●	●		
10 RP	●	●			
10 FP	●				
12 RP	●				

■ Unibody ● Split Body

APPLICABLE STANDARDS

API-American Petroleum Institute

- Spec.6D Specification for pipeline valves.
- Spec.RP6F Recommended practice for fire testing valves.
- Std.598 Valve inspection and test.
- Std.607 Fire test for soft seated quarter-turn valves.

ASME/ANSI-American National Standard

- B16.5 Steel pipe flanges and flanged fittings.
- B16.10 Face-to-face and end-to-end dimensions of ferrous valves.
- B16.34 Steel valves-Flanged and butt welding ends.

Ec-European Community

CE Marked (P.E.D.97/23/EC,Cat.3)

ISO-International Org.for Standardization

- ISO 9001: Quality systems-Model for quality assurance in design/development, production, installation and servicing.
- ISO 15156 Materials for use in H₂S containing environments in oil and gas production.

MSS-Manufacturers Standardization Society

- SP 6 Std. finishes for contact faces of pipe flanges and connecting- end flanges of valves and fittings.
- SP 25 Standard marking system for valves, fittings, flanges and unions.
- SP 44 Steel pipeline flanges.
- SP 55 Quality standard for steel castings visual method.

NACE-National Assoc. of Corrosion Engineers

- MR 0175 Sulfide stress cracking resistant metallic materials for oilfield equipment. (Superseded by ISO 15156)

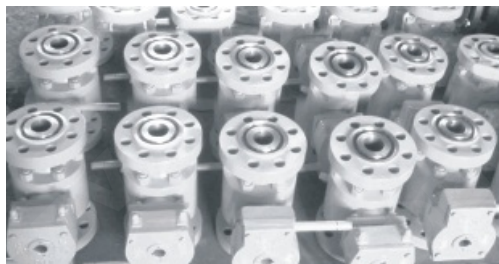

DBV FLOATING BALL VALVES DESIGN FEATURES

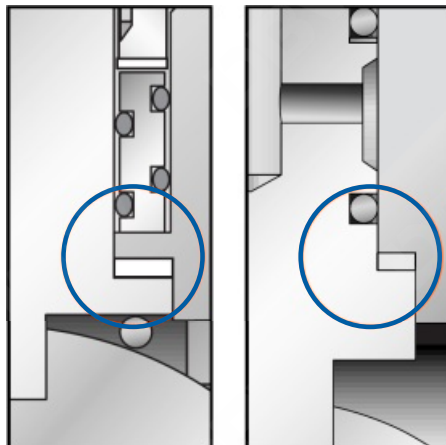

Class 150 & 300

Class 600 & higher

BLOWOUT PROOF STEM.

Internally inserted, "backseated" stem assures fire safety and blow-out prevention by retaining stem in the valve at all pressure.

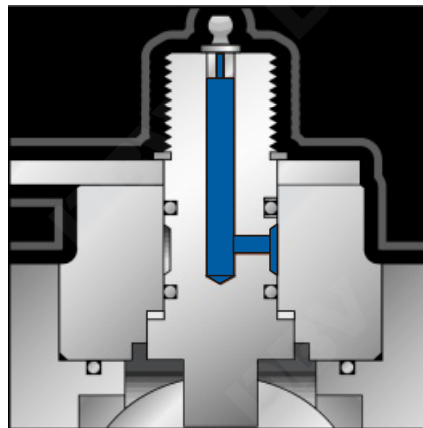

Class 600 & higher

STEM JOURNAL LUBRICATION

All valves incorporate external stem lubrication. A vented weather seal allows safe pressure relief in the event of excessive grease gun pressure

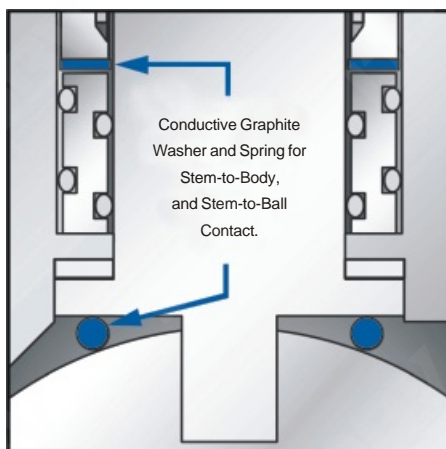

Conductive Graphite Washer and Spring for Stem-to-Body, and Stem-to-Ball Contact.

Class 150 & 300
(O-Ring shown, packing also available.)

ANTISTATIC DEVICE

A conductive spring and a graphite washer provide antistatic continuity throughout the valve.

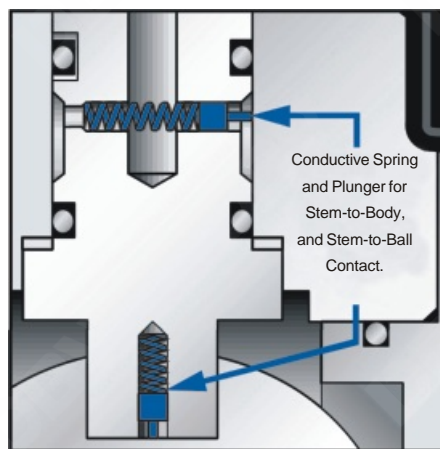

Conductive Spring and Plunger for Stem-to-Body, and Stem-to-Ball Contact.

Class 600 & higher

ANTISTATIC DEVICE

1" bore-4" bore, CL.600,900 & 1500 use spring-loaded pins between the ball, stem, and body to provide antistatic continuity throughout the valve.

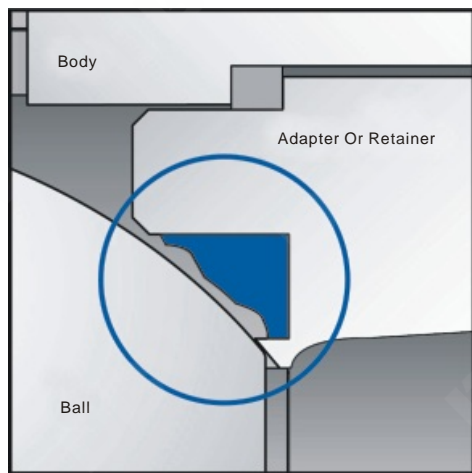

FIRESAFE SEAT SEALING

In the event of fire and seat destruction, ball floats downstream to effectively provide metal-to metal seat sealing.

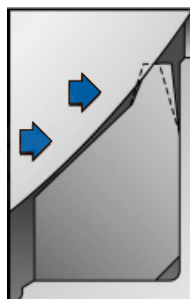

Low Pressure Sealing

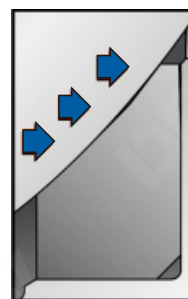

High Pressure Sealing

Positive Low & High Pressure Sealing

A special integral seat Lip provides positive low pressure "bubble-tight" sealing between the ball and seat with minimal operating torque. The DBV seat lip defects slightly at higher pressures to ensure full seat contact with the ball. The seat's "memory action" provides "bubble-tight" sealing at both low and high pressures. This "self compensation for swell" feature results in low torque and long life operation.

● COMPONENT PARTS ● UNI-BODY

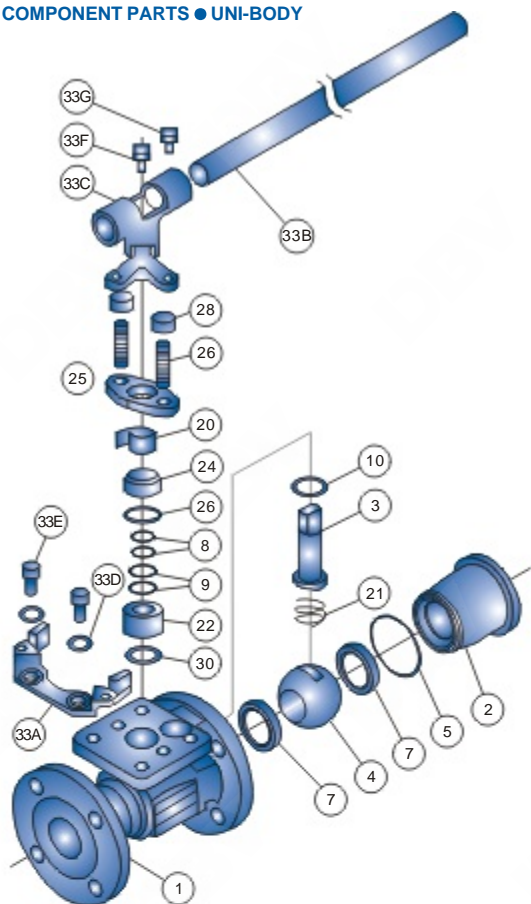

PARTS LIST, UNI-BODY

PART NO	DESCRIPTION	PART NO	DESCRIPTION
1	Body	24	Retainer
2	Seat Retainer	25	Follower
3	Stem	26	Stud, Follower
4	Ball	28	Nut, Follower
5	Body Seal	30	Stem Washer**
7	Seat	33A	Lock Plate
8	Inner Stem O-Rings***	33B	T-Handle Tube
9	Outer Stem O-Rings***	33C	T-Handle Hub
10	Thrust Washer	33D	Lock Washer
20	Liner	33E	Screw, Hex
21	Ground Spring	33F	Screw, Hex
22	Stem Seal: Gland or Packing	33G	Screw, Square
23	Ground Washer*		

*Not required with Graphoil packing in Firesafe valves.

**Required in 2" and larger packed valves only.

***Not used in packed stem valves.

● COMPONENT PARTS ● SPLIT BODY

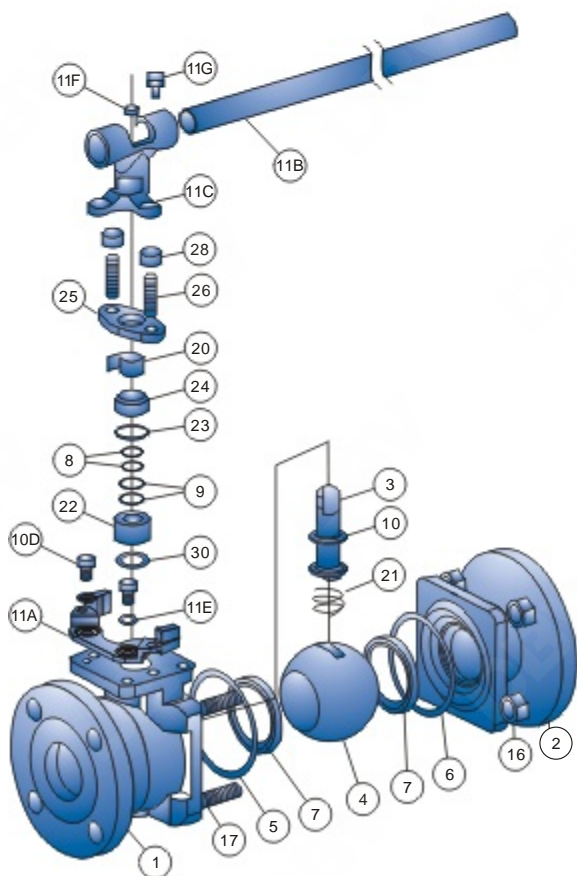

PARTS LIST, SPLIT BODY

PART NO	DESCRIPTION	PART NO	DESCRIPTION
1	Body	11E	Lock Plate Lock Washer
2	Adapter	11F	Handle Hub Screw
3	Stem	11G	Tube Lock Screw
4	Ball	16	Hex Nut
5	Body Gasket	17	Stud
6	Body O-Ring***	20	Follower Liner
7	Seat	21	Ground Spring
8	Inner Stem O-Rings***	22	Stem Seal : Gland or Packing
9	Outer Stem O-Rings***	23	Ground Washer*
10	Thrust Bearing	24	Packing Follower
11A	Lock Plate	25	Packing Retainer
22B	T-Handle Tube	26	Packing Stud
11C	T-Handle Hub	28	Packing Nut
11D	Lock Plate Screw	30	Stem Washer**

*Not required with Graphoil packing in Firesafe valves.

**Required in 2" and larger packed valves only.

***Not used in packed stem valves.

● COMPONENT PARTS ● CLASS 600, 900 & 1500

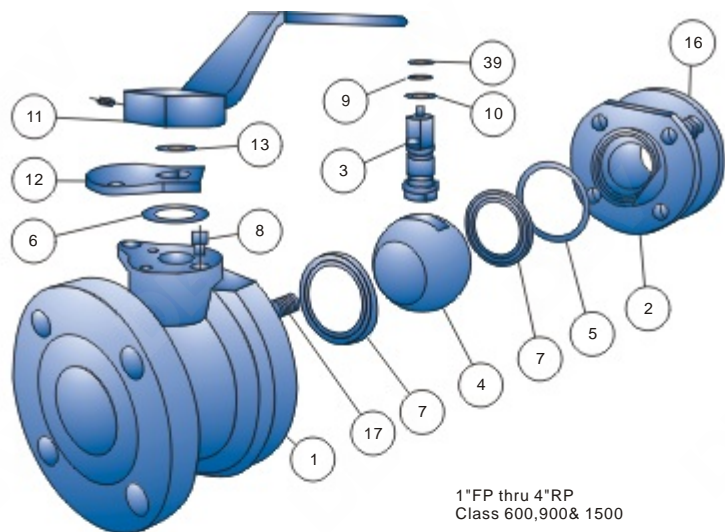

PARTS LIST

PART NO	DESCRIPTION
1	Body
2	Adapter
3	Stem
4	Ball
5	Body Seal
6	Stem Bearing
7	Seat
8	Stop Screw
9	Stem Seal
10	Thrust Bearing
11	Handle Assembly
12	Stop Plate
13	Retainer
16	Hex Nut
17	Stud
39	Weather Seal

● COMPONENT PARTS ● CLASS 600

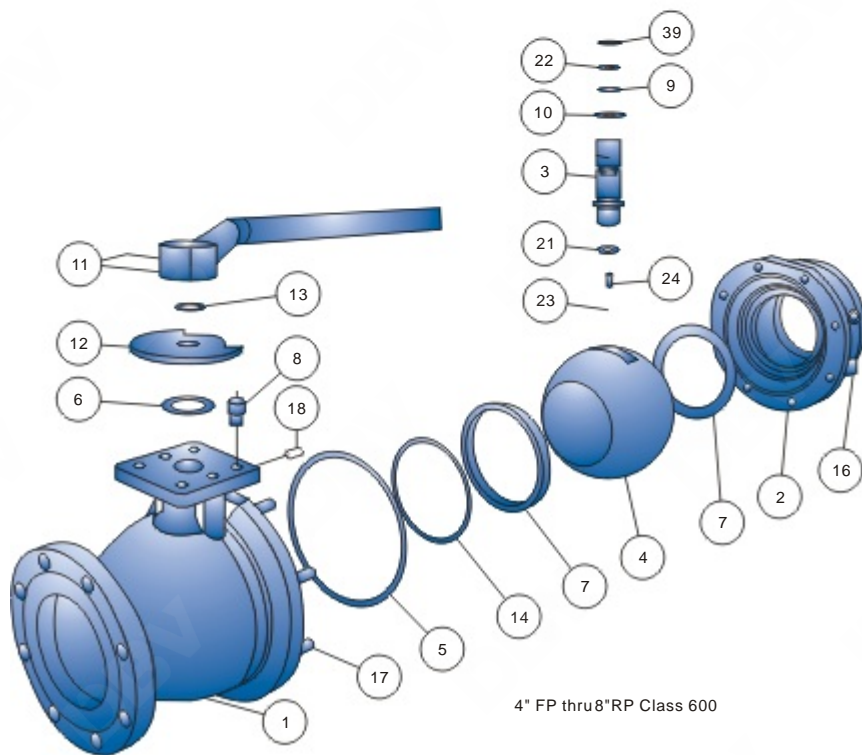

PARTS LIST

PART NO	DESCRIPTION
1	Body
2	Adapter
3	Stem
4	Ball
5	Body Seal
6	Stem Bearing
7	Seat
8	Stop Screw
9	Stem Seal
10	Thrust Bearing
11	Handle Assembly
12	Stop Plate*
13	Retainer*
14	Adapter Pilot Seal
16	Hex Nut
17	Stud
18	Lube Fitting
21	Ground Spring**
22	Firesafe Stem Packing
23	Ground Plunger*
24	Ground Spring*
39	Weather Seal

*4" Bore Only
**6" Bore Only

UNI-BODY BALL VALVE

- One Piece Uni-body, ReducedBore
- Free Floating Ball, Fire Safe, Blow-out Proof Stem
- Anti-static Device, Cavity Relieving Seats
- NACE MR-01-75, Optional Locking Device
- Designed to ASME B16.34, BS5451 & API6D

Face to Face	ASME B16.10 (Short Pattern)
End Flange	ASME B16.5
Buttweld	ASME B16.25
Class	ASME CL150

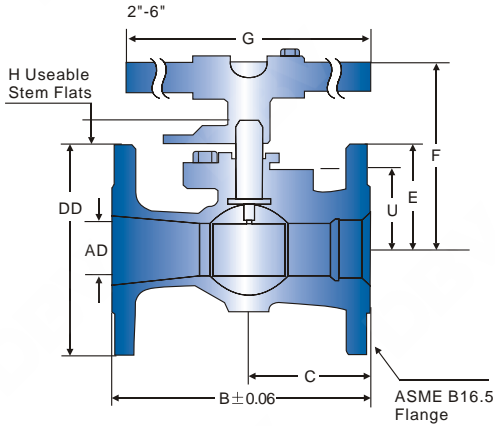

CLASS 150 DIMENSION

SIZE (in.)	A	B	C	D	E	F	G	H	U	W.T (lbs.)
2	1.50	7.00	3.27	6.00	3.69	5.36	17.00	0.70	2.31	17.6
3	2.42	8.00	3.46	7.50	4.38	6.05	17.00	0.70	3.06	31.5
4	3.00	9.00	4.10	9.00	6.75	8.83	22.00	1.38	4.43	54.2
6	4.50	10.50	5.25	11.00	8.56	10.55	22.00	1.44	6.02	137.0

Unit: inch

UNI-BODY BALL VALVE

- One Piece Uni-body, ReducedBore
- Free Floating Ball, Fire Safe, Blow-out Proof Stem
- Anti-static Device, Cavity Relieving Seats
- NACE MR-01-75, Optional Locking Device
- Designed to ASME B16.34, BS5451 & API6D

Face to Face	ASME B16.10 (Short Pattern)
End Flange	ASME B16.5
Buttweld	ASME B16.25
Class	ASME CL300

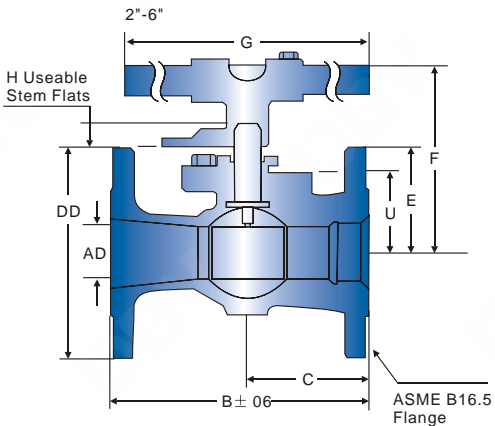

CLASS 300 DIMENSION

SIZE (in.)	A	B	C	D	E	F	G	H	U	W.T (lbs.)
2	1.50	8.50	3.27	6.50	3.69	5.36	17.00	.70	2.31	26.0
3	2.42	11.12	3.96	8.25	4.38	6.05	17.00	.70	3.06	46.0
4	3.00	12.00	4.10	10.00	6.75	8.83	22.00	1.38	4.43	70.0
6	4.50	15.88	5.25	12.50	8.56	10.55	22.00	1.44	6.02	157.0

Unit: inch

SPLIT BODY BALL VALVE

- Two Piece Split Body, Full Portor Reduced Bore
- Free Floating Ball, Fire Safe, Blow-out Proof Stem
- Anti-static Device, Cavity Relieving Seats
- NACE MR-01-75, Optional Locking Device
- Designed to ASME B16.34, BS5451 & API 6D

Face to Face	ASME B16.10 (Long Pattern)
End Flange	ASME B16.5
Buttweld	ASME B16.25
Class	ASME CL150

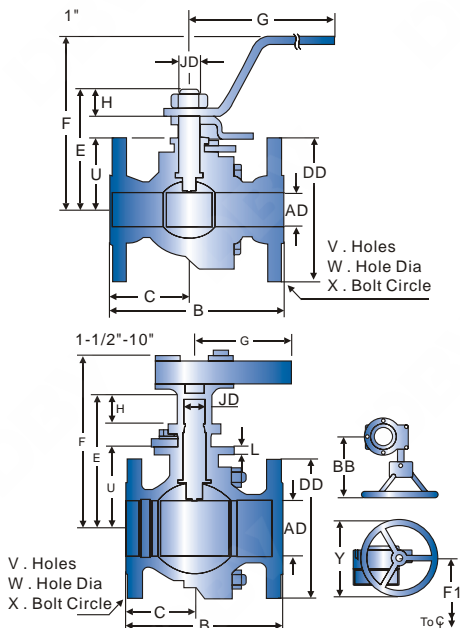

CLASS 150 DIMENSION

SIZE (in.)	A	B	C	D	E	F	F1	G	Unit: inch
1X1	1.00	5.00	2.31	4.25	3.50	5.44	-	6.31	
1-1/2X1-1/2	1.50	6.50	2.96	5.00	3.69	5.75	7.37	15.50	
2X2	2.00	7.00	3.02	6.00	4.51	6.56	8.20	15.50	
2-1/2X2	2.00	7.50	2.94	7.00	4.38	6.06	-	8.50	
3X3	3.00	8.00	3.50	7.50	6.81	10.25	11.63	20.00	
4X4	4.00	9.00	4.00	9.00	8.40	11.00	13.08	20.00	
6X6	6.00	15.50	7.75	11.00	10.81	11.12	15.63	20.00	
8X6	6.00	11.50	5.13	13.50	10.81	11.12	15.63	20.00	
8X8	8.00	18.00	9.00	13.50	14.25	-	18.26	20.00	
10X8	8.00	13.00	6.50	16.00	14.25	-	18.26	-	
10X10	10.00	21.00	10.50	16.00	17.41	-	22.53	-	
12X10	10.00	14.00	7.00	19.00	17.41	-	22.53	-	

SIZE (in.)	H	J	L	U	V	W	X	Y	BB	W.T (lbs.)	Unit: inch
1X1	1.32	0.586	-	1.69	4	0.63	3.13	-	-	17.0	
1-1/2X1-1/2	0.64	0.705	0.38	2.31	4	0.63	3.88	6.00	6.50	12.8	
2X2	0.64	0.705	0.44	3.14	4	0.75	4.75	6.00	6.50	17.6	
2-1/2X2	1.00	0.873/0.871	-	3.06	4	0.75	5.50	-	-	37.5	
3X3	1.28	1.087/1.082	0.44	4.43	4	0.75	6.00	6.00	6.50	31.5	
4X4	1.28	1.321/1.316	0.62	5.88	8	0.75	7.50	8.00	9.00	54.2	
6X6	1.45	1.515/1.510	0.75	8.00	8	0.88	9.50	8.00	9.50	137	
8X6	1.45	1.515/1.510	0.75	8.00	8	0.88	9.50	8.00	9.50	210	
8X8	2.27	1.997/1.994	0.62	9.64	8	0.88	9.50	12.00	9.50	477	
10X8	2.27	1.997/1.994	0.62	9.64	12	1.00	14.25	12.00	9.50	557	
10X10	3.06	2.497/2.493	0.62	11.91	12	1.00	14.25	16.00	11.50	685	
12X10	3.06	2.497/2.493	0.62	11.91	12	1.00	17.00	16.00	11.50	806	

SPLIT BODY BALL VALVE

- Two Piece Split Body, Full Portor Reduced Bore
- Free Floating Ball, Fire Safe, Blow-out Proof Stem
- Anti-static Device, Cavity Relieving Seats
- NACE MR-01-75, Optional Locking Device
- Designed to ASME B16.34, BS5451 & API 6D

Face to Face	ASME B16.10 (Long Pattern)
End Flange	ASME B16.5
Buttweld	ASME B16.25
Class	ASME CL300

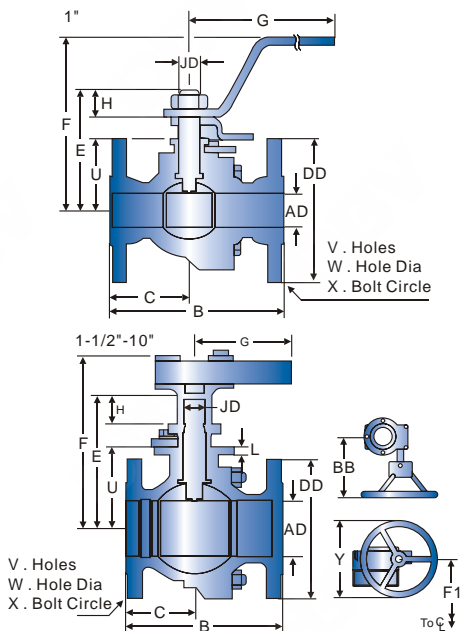

CLASS 300 DIMENSION

SIZE (in.)	A	B	C	D	E	F	F1	G	Unit: inch
1X1	1	6.50	3.50	4.88	3.50	5.44	-	6.31	
1-1/2X1-1/2	1.50	7.50	3.53	6.13	3.69	5.75	7.37	15.50	
2X2	2.00	8.50	4.25	6.50	4.51	6.56	8.20	15.50	
2-1/2X2	2.00	9.50	4.69	7.50	4.38	6.06	-	8.50	
3X3	3.00	11.13	5.82	8.25	6.81	10.25	11.63	20.00	
4X4	4.00	12.00	6.00	10.00	8.40	11.00	13.08	20.00	
6X6	6.00	15.88	7.94	12.50	12.75	-	15.63	-	
8X6	6.00	16.50	6.63	15.00	12.75	-	15.63	-	
8X8	8.00	19.75	9.88	15.00	16.00	-	21.14	-	
10X8	8.00	18.00	6.25	17.50	16.00	-	21.14	-	

SIZE (in.)	H	J	L	U	V	W	X	Y	BB	W.T (lbs.)	Unit: inch
1X1	1.32	0.586	-	1.69	4	0.75	3.50	-	-	22.0	
1-1/2X1-1/2	0.64	0.705	0.38	2.31	4	0.88	4.50	6.00	6.50	20.0	
2X2	0.64	0.705	0.44	3.14	8	0.78	5.00	6.00	6.50	26.0	
2-1/2X2	1.00	0.873/0.871	-	3.06	8	0.88	5.88	-	-	43.7	
3X3	1.28	1.087/1.062	0.44	4.43	8	0.88	6.63	6.00	6.50	46.0	
4X4	1.28	1.321/1.316	0.62	5.88	8	0.88	7.88	8.00	9.00	70.0	
6X6	2.27	1.950/1.945	0.62	8.12	12	0.88	10.63	12.00	9.50	157	
8X6	2.27	1.950/1.945	0.62	8.12	12	1.00	13.00	12.00	9.50	275	
8X8	3.06	2.497/2.492	0.62	10.52	12	1.00	13.00	16.00	11.50	624	
10X8	3.06	2.497/2.492	0.62	10.52	16	1.13	15.25	16.00	11.50	724	

SPLIT BODY BALL VALVE

- Two Piece Split Body, Full Portor Reduced Bore
- Free Floating Ball, Fire Safe, Blow-out Proof Stem
- Anti-static Device, Cavity Relieving Seats
- NACE MR-01-75, Optional Locking Device
- Designed to ASME B16.34, BS5451 & API 6D

Face to Face	ASME B16.10 (Long Pattern)
End Flange	ASME B16.5
Buttweld	ASME B16.25
Class	ASME CL600

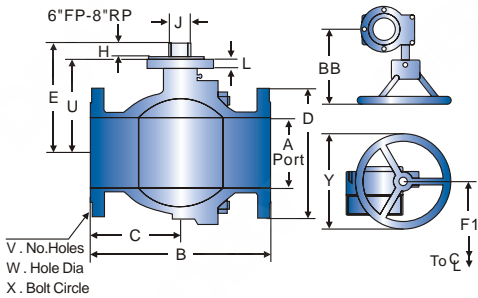
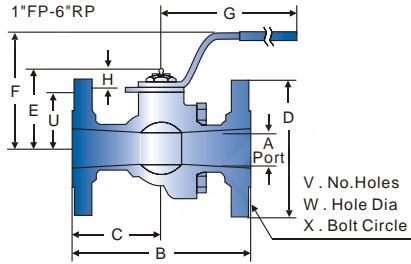

CLASS 600 DIMENSION

SIZE (in.)	A	B/RF	B/RTJ	C/RF	C/RTJ	D	E	F	G
1FP	1	8-1/2	8-1/2	3-3/4	3-3/4	4-7/8	3	4-3/16	5-7/8
1-1/2FP	1-1/2	9-1/2	9-1/2	3-7/8	3-7/8	6-1/8	3-15/16	5-5/8	8-1/2
2RP	1-1/2	11-1/2	11-5/8	4-7/16	4-1/2	6-1/2	3-15/16	5-5/8	8-1/2
2FP	2	11-1/2	11-5/8	4-7/16	4-1/2	6-1/2	4-3/8	6-1/16	8-1/2
2-1/2RP	2	13	13-1/8	4-15/16	5	7-1/2	4-3/8	6-1/16	8-1/2
3RP	2	14	14-1/8	6	6-1/16	8-1/4	4-3/8	6-1/16	8-1/2
3FP	3	14	14-1/8	5-3/4	5-13/16	8-1/4	5-21/32	7-1/4	15
4RP	3	17	17-1/8	7-3/4	7-13/16	10-3/4	5-21/32	7-1/4	15
4FP	4	17	17-1/8	8-1/2	8-9/16	10-3/4	8-19/32	9-1/2	48
6RP	4	22	22-1/8	11	11-1/16	14	8-19/32	9-1/2	48
6FP	6	22	22-1/8	11	11-1/16	14	11-3/4	-	-
8RP	6	26	26-1/8	13	13-1/16	16-1/2	11-3/4	-	-

Unit: inch

SIZE (in.)	H	J	L	U	V	W	X	W.T (lbs.)	Ring Groove
1FP	13/16	0.623/0.621	-	1-11/16	4	3/4	3-1/2	25	R-16
1-1/2FP	1	0.873/0.871	-	2-5/8	4	7/8	4-1/2	30.4	R-20
2RP	1	0.873/0.871	-	2-5/8	8	3/4	5	35	R-23
2FP	1	0.873/0.871	-	3-1/16	8	3/4	5	41.5	R-23
2-1/2RP	1	0.873/0.871	-	3-1/16	8	7/8	5-7/8	52.9	R-26
3RP	1	0.873/0.871	-	3-1/16	8	7/8	6-5/8	61.6	R-31
3FP	1-1/4	1.248/1.246	-	4	8	7/8	6-5/8	89.1	R-31
4RP	1-1/4	1.248/1.246	-	4	8	1	8-1/2	133.8	R-37
4FP	1-11/16	1.791/1.773	1/2	6.5	8	1	8-1/2	167	R-37
6RP	1-11/16	1.791/1.773	1/2	6.5	12	1-1/8	11-1/2	345	R-45
6FP	2-7/8	2.499/2.492	5/8	8-25/32	12	1-1/8	11-1/2	427	R-45
8RP	2-7/8	2.499/2.492	5/8	8-25/32	12	1-1/4	13-3/4	672	R-49

Unit: inch

Note: Sizes 1"FP-6"RP is weight w/handle.
 Sizes 6"FP-8"RP is weight w/gear operator.

SPLIT BODY BALL VALVE

- Two Piece Split Body, Full Portor Reduced Bore
- Free Floating Ball, Fire Safe, Blow-out Proof Stem
- Anti-static Device, Cavity Relieving Seats
- NACE MR-01-75, Optional Locking Device
- Designed to ASME B16.34, BS5451 & API 6D

Face to Face	ASME B16.10 (Long Pattern)
End Flange	ASME B16.5
Buttweld	ASME B16.25
Class	ASME CL900-CL1500

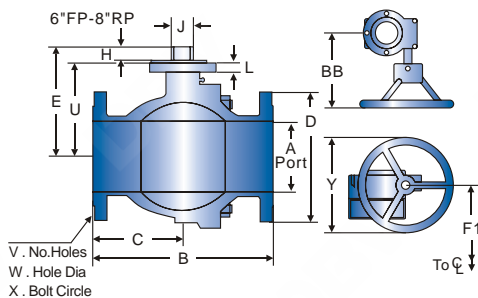
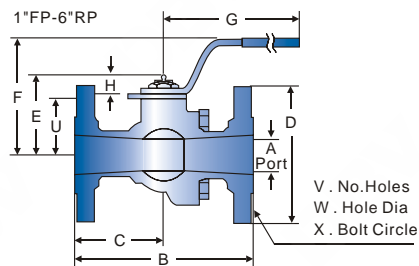

CLASS 900/1500 DIMENSION

SIZE (in.)	A	B/RF	B/RTJ	C/RF	C/RTJ	D	E	F	G
1FP	1	10	10	4-3/4	4-3/4	5-7/8	3-1/16	4-1/2	5-7/8
2RP	1-1/2*	14-1/2*	14-5/8*	7-1/4*	7-5/16*	8-1/2*	3-15/16*	5-5/8*	8-1/2*
2FP	2*	14-1/2*	14-5/8*	7-1/4*	7-5/16*	8-1/2*	4-3/8*	6-1/16*	8-1/2*

Unit: inch

SIZE (in.)	H	J	L	U	V	W	X	W.T (lbs.)	Ring Groove
1FP	1-1/8	.623/.621	-	2	4	1	4	28	R-16
2RP	1-1/16*	.873/.871*	-	2-5/8*	8*	1*	6-1/2*	42.9*	R-24*
2FP	1-1/16*	.873/.871*	-	3-1/16*	8*	1*	6-1/2*	51.2*	R-24*

Unit: inch

Note: Weight is w/handle
 * Class 900 only

ENGINEERING DATA PRESSURE TEMPERATURE (SIZES LISTED ON TEFLON CHART INDICATE BORE SIZE)

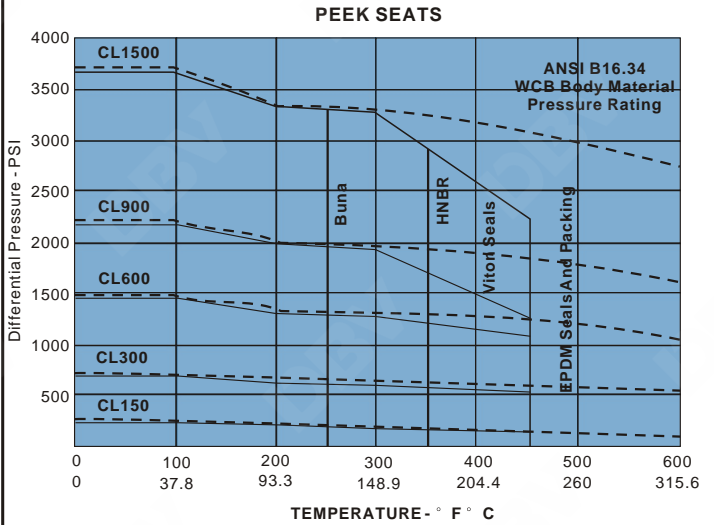
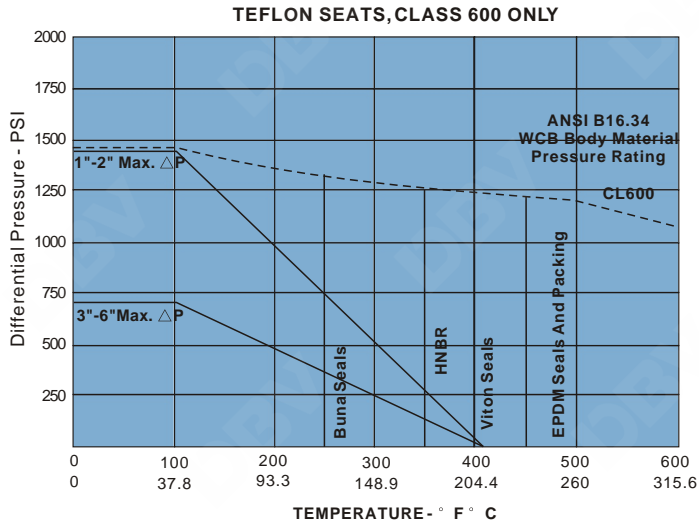

LOW TEMPERATURE LIMITS

BODY MATERIAL	° F	° C	SEAT MATERIAL	° F	° C	SEAT MATERIAL	° F	° C	SEAT MATERIAL	° F	° C
WCC	-20°	-28.9	Devlon V	-50°	-45.6	TFE Packing	-50°	-45.6	Viton	+10°	-12.2
LCC	-50°	-45.6	Teflon	-50°	-45.6	Low Temp Buna N	-50°	-45.6	HNBR	-40°	-40
WCB	-20°	-28.9	PEEK	-50°	-45.6	Viton	-20°	-28.9	EPDM	-50°	-45.6
CF8M	-50°	-45.6				Elast-0-Lion 985	-50°	-45.6			

FLOW COEFFICIENT (CV)

Class	1FP	1-1/2FP	2RP	2FP	2-1/2RP	3RP	3FP	4RP	4FP	6RP	6FP	8RP	8FP	10RP	10FP	12RP
150	98	265	125	470	220	430	1240	600	2470	1010	5249	2500	10.750	5000	17.775	8400
300	98	265	125	420	220	430	1050	600	2000	1010	5100	2400	10.300	4825	-	-
600	93	308	140	365	220	185	1000	570	1800	900	4600	2235	-	-	-	-
900/1500	90	-	135*	350*	-	-	-	-	-	-	-	-	-	-	-	-

*Class 900 only

METHOD OF CALCULATING FLOW

The Flow Coefficient "Cv" of a valve is the flow rate of water (gallons/minute) through a fully opened valve, with a pressure drop of 1psi across the valve. To find the flow of liquid through valve from the Cv, use the following formulas:

Liquid Flow

QL = flow rate of liquid (gal./min.)

ΔP = differential pressure across the valve (psi)

G = specific gravity of liquid (for water, G=1)

$$Q_L = C_v \sqrt{\frac{\Delta P}{G}}$$

Gas Flow

Qg = flow rate of gas (CFH at STP)

P₂ = outlet pressure (psia)

g = Specific gravity of gas (for air, g=1.000)

$$Q_g = 61 C_v \sqrt{\frac{P_2 \Delta P}{g}}$$

For non-critical flow

$$\left\{ \frac{\Delta P}{P_2} < 1.0 \right\}$$



UNI-BODY BALL VALVE

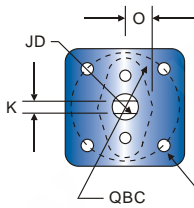

(4) Tapped Holes "S" Thread Thru Spaced Equally On "Q" Dia. B.C. Straddling Center Lines As Shown

TOPWORKS (IN.) & STEM TORQUE (IN.-LBS) UNIBODY BALL VALVES, CLASS 150&300

SIZE (in.)	Class	J	K	O	Q	S	Unit: inch
2	150/300	0.705	0.376/0.373	0.81	3.25	3/8-16 UNC	
3	150/300	0.705	0.376/0.373	0.81	3.25	3/8-16 UNC	
4	150/300	1.06	0.674/0.670	1.36	4.13	3/8-16 UNC	
6	150/300	1.32	0.865/0.861	1.36	4.41	1/2-13 UNC	

SPLIT BODY BALL VALVE CL150/300

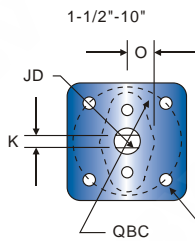
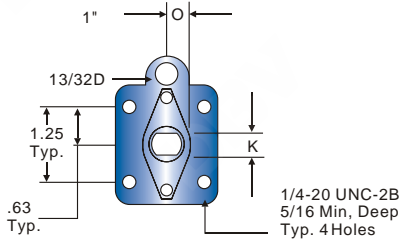

(4) Tapped Holes "S" Thread Thru Spaced Equally On "Q" Dia. B.C. Straddling Center Lines As Shown

SPLIT BODY BALL VALVE CL150/300

SIZE (in.)	Class	J	K	O	Q	S	Unit: inch
1X1	150/300	0.586	0.371/0.369	0.56	-	1/4-20 UNC	
1-1/2X1-1/2	150/300	0.705	0.376/0.373	0.76	3.25	3/8-16 UNC	
2X2	150/300	0.705	0.376/0.373	0.76	3.25	3/8-16 UNC	
2-1/2X2	150/300	0.873/0.871	0.560/0.556	-	1.75	1/4-20 UNC	
3X3	150/300	1.067/1.062	0.674/0.670	1.36	4.13	3/8-16 UNC	
4X4	150/300	1.321/1.316	0.865/0.861	1.36	4.41	1/2-13 UNC	
6X6	150	1.515/1.510	1.065/1.061	1.36	5.13	5/8-11 UNC	
6x6	300	1.950/1.945	1.249/1.245	1.58	5.13	5/8-11 UNC	
8X6	150	1.575/1.570	1.065/1.061	1.36	5.13	5/8-11 UNC	
8x6	300	1.950/1.945	1.249/1.245	1.58	5.13	5/8-11 UNC	
8X8	150	1.997/1.992	1.247/1.243	1.58	5.13	5/8-11 UNC	
8x8	300	2.497/2.492	1.747/1.743	2.10	6.75	3/4-10 UNC	
10X8	150	1.997/1.992	1.247/1.243	1.58	5.13	5/8-11 UNC	
10x8	300	2.497/2.492	1.747/1.743	2.10	6.75	3/4-10 UNC	
10X10	150	2.497/2.492	1.747/1.743	2.10	6.75	3/4-10 UNC	
12X10	150	2.497/2.492	1.747/1.743	2.10	6.75	3/4-10 UNC	

SPLIT BODY BALL VALVE CL 600~1500

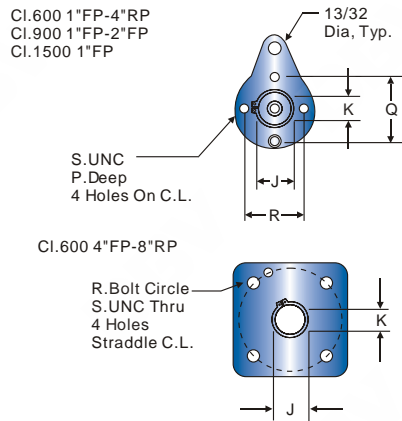

SPLIT BODY BALL VALVE CL 600~1500

SIZE (in.)	Class	J	K	P	Q	R	S	Unit: inch
1FP	600	0.623/0.621	0.372/0.370	5/16	1-1/4	1-1/4	1/4-20 UNC	
1FP	900	0.623/0.621	0.372/0.370	5/16	1-1/4	1-1/4	1/4-20 UNC	
1FP	1500	0.623/0.621	0.372/0.370	5/16	1-1/4	1-1/4	1/4-20 UNC	
1-1/2 FP	600	0.873/0.871	0.560/0.566	3/8	1-3/4	1-3/4	1/4-20 UNC	
2RP	600/900	0.873/0.871	0.560/0.566	3/8	1-3/4	1-3/4	1/4-20 UNC	
2-1/2RP	600	0.873/0.871	0.560/0.566	3/8	1-3/4	1-3/4	1/4-20 UNC	
2FP	600/900	0.873/0.871	0.560/0.566	3/8	1-3/4	1-3/4	1/4-20 UNC	
3RP	600	0.873/0.871	0.560/0.566	3/8	1-3/4	1-3/4	1/4-20 UNC	
3FP	600	1.248/1.246	0.622/0.618	5/8	3-1/8	2-1/4	5/16-18 UNC	
4RP	600	1.248/1.246	0.622/0.618	5/8	3-1/8	2-1/4	5/16-18 UNC	
4FP	600	1.791/1.773	1.247/1.243	thru	-	4-1/4	7/16	
6RP	600	1.791/1.773	1.247/1.243	thru	-	4-1/4	7/16	
6FP	600	2.499/2.492	1.749/1.745	thru	-	6-3/4	3/4-10 UNC	
8RP	600	2.499/2.492	1.749/1.745	thru	-	6-3/4	3/4-10 UNC	

DESIGN TORQUES FOR ACTUATOR SIZING (IN.-LBS.)*

Class/ Work. Press. (psi)	Valve Size (in.)															
	1FP	1-1/2 FP	2RP	2FP	2-1/2 RP	3RP	3FP	4RP	4FP	6RP	6FP	8RP	8FP	10RP	10FP	12RP
150/285	180	280	240	440	600	520	600	600	1440	1440	5500	5500	12.000	12.000	23.000	23.000
300/740	180	280	240	500	960	590	1000	1000	2500	2500	12.000	12.000	27.000	27.000	-	-
600/1480	600	900	900	1200	1200	1200	2700	2700	5280	5280	27.000	27.000	-	-	-	-
900/2220	780	-	1320	1800	-	-	-	-	-	-	-	-	-	-	-	-
1500/3705	1200	-	-	-	-	-	-	-	-	-	-	-	-	-	-	-

*There is no safety factor in the above torques. DBV recommends at least a 25% safety factory be added.

DBV 3-PIECE BOLTED BALL VALVES

- Carbon Steel Body/Stainless Steel Trim
- All Stainless Steel Construction
- Threaded, Socket Weld or Butt Weld Ends
- 3/4"-2-1/2" Standard Port
- 1-4"-2" Full Port
- Operating Pressures to 3000 WOG

GENERAL DESIGN FEATURES

1. Internal Entry Stem
2. Handle With Slide Lock (Optional)
3. ISO 5211 Direct Mount
Actuator Mounting Pad (Optional)
4. Live Loaded High Cycle,
TFE V-Ring Style Packing
5. Body Seals For High Temp &
API 607 Applications
6. Integral Fire Lip
7. Threaded, Socket Weld & Butt Weld
End Connections Available
8. Full ANSI Class 600 Wall Thicknesses

AVAILABLE SEAT MATERIALS

Mineral Filled PTFE
PEEK
Delrin

Available End Connections

Female NPTF
Socket Weld
Butt Weld (Specify Pipe Schedule)



SPECIFICATIONS

MSS SP-110	ANSI B16.34
ANSI B1.20.3	API 598
ANSI B16.11	API 607
ANSI B16.25	

• Size

1/4-2-1/2	Standard Port
3/4-2	Full Port

• Body Material

Carbon Steel, WCB
Stainless Steel, CF8/ CF8M

• Construction

Bolted Cover or Unibody

• Port

Standard Port
Full Port

• End Connection

NPT
Socket Weld
Butt Weld
NPT x Socket Weld
NPT x Butt Weld

• Seat & Seal Material

Standard Options	
Seat	Packing/Body Seal
Mineral Filled	PTFE
PEEK	Graphite
Delrin	PTFE / PTFE
Firesafe Options	
Mineral Filled PTFE	Graphite

• Ball & Stem

316 Stainless Steel (17-4 Stem)

• Packing

PTFE, Standard Trim
Graphite, API 607 4th Edition Firesafe

• Configuration

Live Loaded Stem

• Options

Lever Locking Handle
Oval Locking Handle
Extended Locking
Extended Oval Locking
TFE Coated 316SS
Vented Ball
Carbon Bolting
Oxygen Cleaned
Grounded Ball & Stem

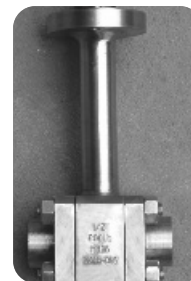

DBV THREADED, WELDED & GROOVED-END FLOATING BALL VALVES GENERAL DESIGN FEATURES

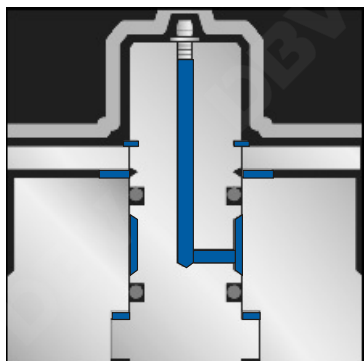

STEM JOURNAL LUBRICATION

Valves that utilize an external stem lubrication fitting also incorporate a vented weather seal which allows safe pressure relief in the event of excessive grease gun pressure.

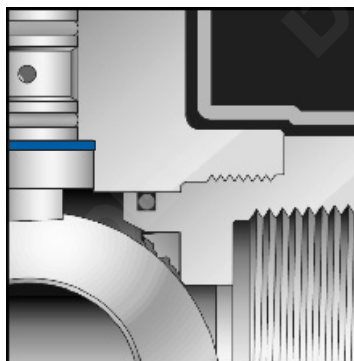

FIRESAFE DESIGN/ CERTIFIED

Upon destruction of the seat (in the event of a fire) the ball floats downstream to provide metal-to-metal contact behind the seat area. Pressure assisted shut-off prevents fire feeding leakage.

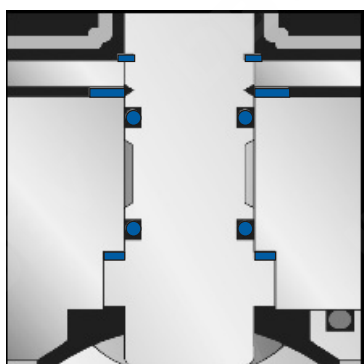

BLOWOUT PROOF STEM

Internally inserted "back-seated" stem assures fire safety and blowout prevention by retaining stem in the valve at all pressures.

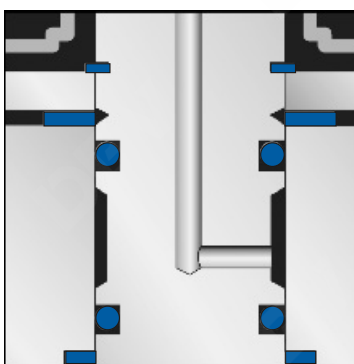

WEATHER SEAL

Weather seals are utilized in most DBV Ball Valves to effectively eliminate stem journal corrosion, abrasion and galling. (Optional)



FIGHT THE COST OF CORROSION

Prolong the life of your Valves by reducing corrosion with anti-corrosive Coating. Consult factory for more information.



SECURE YOUR INVESTMENT

A majority of the Threaded/ Grooved Ball Valves come standard with an integral locking ear to prevent unauthorized operations.

*Padlocks not included.



STANDARD HANDLE, STEM WRENCH AREA

DBV Ball Valves are equipped with durable handles as a standard feature, Valves can also be provided with square nut assemblies. The heavy-duty flattened stem design allows usage of standard wrenches when necessary to conserve space and prevent accidental operation

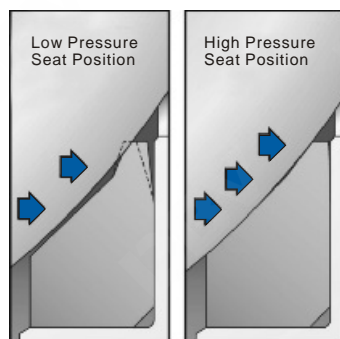

LOW PRESSURE SEAT POSITION

An integral seat lip provides positive low pressure "bubble-tight" sealing of ball and seat. The assembly preload insures constant surface load of ball to seat with minimal operating torque.

HIGH PRESSURE SEAT POSITION

The DBV seat lip deflects slightly at higher pressures to ensure full seat-to-ball contact. The seat's "memory-action" provides bubble-tight sealing at low and high pressures. This "self compensation for swell" feature results in low torque and long life operation.

2PCS FORGED STEEL BALL VALVES

- Internal Entry Stem
- Handle With Slide Lock (Optional)
- ISO 5211 DirectMount
Actuator Mounting Pad (Optional)
- Body Seals For High Temp & API 607 Applications
- Forged Carbon or Stainless Steel Floating Ball Valve
- Two Piece Split Body, Available in Standard or Full Port
- Ends Connections in Threaded NPT, Socket Weld, Butt-weld, NPT x S.W, NPT x B.W
- Designed & Manufactured to BS5351, MSS-SP-118

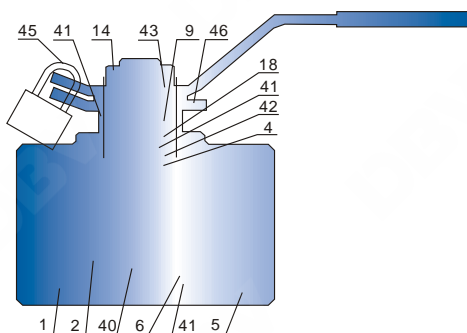

MAIN PART MATERIALS LIST

NO.	Part name	A105/F6a	LF2/304	F304(L)/304(L)	F316 (L)/316(L)	F51/F51
1	Body	A105	LF2	F304(L)	F316(L)	F51
2	Seat	RPTFE & PEEK	RPTFE & PEEK	RPTFE & PEEK	RPTFE & PEEK	RPTFE & PEEK
4	Stem	410	304	304(L)	316(L)	F51
5	Gasket	PTFE	PTFE	PTFE	PTFE	PTFE
6	Bonnet	A105	LF2	F304	F316	F51
9	Gland	410	304	304(L)	316(L)	F51
11	Gland Flange	A105	LF2	F304	F316	F51
14	Flat nut	8	8	8	8M	8M
18	Packing	PTFE	PTFE	PTFE	PTFE	PTFE
40	Ball	F6	F304	F304(L)	F316(L)	F51
41	O-ring	VITON	VITON	VITON	VITON	VITON
42	Back seat gasket	RPTFE & PEEK	RPTFE & PEEK	RPTFE & PEEK	RPTFE & PEEK	RPTFE & PEEK
43	Wrench	ANSI 10 25	ANSI 10 25	ANSI 10 25	ANSI 10 25	ANSI 10 25
44	Screw	B8	B8	B8	B8M	B8M
45	Lock	Finished product	Finished product	Finished product	Finished product	Finished product
46	Locator	ANSI 10 25	ANSI 10 25	ANSI 10 25	ANSI 10 25	ANSI 10 25

3PCS FORGED STEEL BALL VALVES

- Internal Entry Stem
- Handle With Slide Lock (Optional)
- ISO 5211 DirectMount
Actuator Mounting Pad (Optional)
- Body Seals For High Temp & API 607 Applications
- Forged Carbon or Stainless Steel Floating Ball Valve
- Three Piece Bolted Body, Available in Standard or Full Port
- Ends Connections in Threaded NPT, Socket Weld, Butt-weld, NPT x S.W, NPT x B.W
- Designed & Manufactured to BS5351, MSS-SP-118

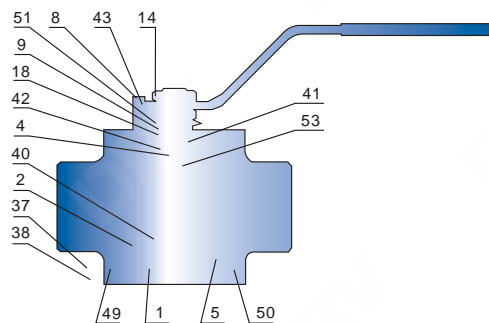

MAIN PART MATERIALS LIST

NO.	Part name	A105/F6a	LF2/304	F304(L)/304(L)	F316 (L)/316(L)	F51/F51
1	Body	A105	LF2	F304(L)	F316(L)	F51
2	Seat	RPTFE & PEEK	RPTFE & PEEK	RPTFE & PEEK	RPTFE & PEEK	RPTFE & PEEK
4	Stem	410	304	304(L)	316(L)	F51
5	Gasket	PTFE	PTFE	PTFE	PTFE	PTFE
8	Pin	25	304	304	304	304
9	Gland	410	304	304(L)	316(L)	F51
14	Flat nut	8	8	8	8M	8M
18	Packing	PTFE	PTFE	PTFE	PTFE	PTFE
37	Bolt	B7	B8	B8	B8M	B8M
38	Nut	2H	8	8	8M	8M
40	Ball	F6	F304	F304(L)	F316(L)	F51
41	O-ring	VITON	VITON	VITON	VITON	VITON
42	Back seat gasket	RPTFE & PEEK	RPTFE & PEEK	RPTFE & PEEK	RPTFE & PEEK	RPTFE & PEEK
43	Wrench	ANSI 10 25	ANSI 1025	ANSI 1025	ANSI 1025	ANSI 1025
49	Left bonnet	A105	LF2	F304	F316	F51
50	Right bonnet	A105	LF2	F304	F316	F51
51	Butterfly spring	65Mn	65Mn	304	304	304
52	Elastic washer	65Mn	65Mn	304	304	304
53	Anti-static spring	304	304	304	316L	316L

ONE PIECE CASTED BALL VALVE

- Investment Casting One Piece Uni-body, Standard Bore
- Free Floating Ball, Fire Safe, Blow-out Proof Stem
- Anti-static Device, Cavity Relieving Seats
- Optional Locking Device & ISO5211 Mounting Pad
- Designed to ASME B16.34

Face to Face	DBV Standard
Threaded Ends	Rc to BS21, NPT to ASME B1.20.1
Socketed Ends	ASME B16.11
Class	1000Psi

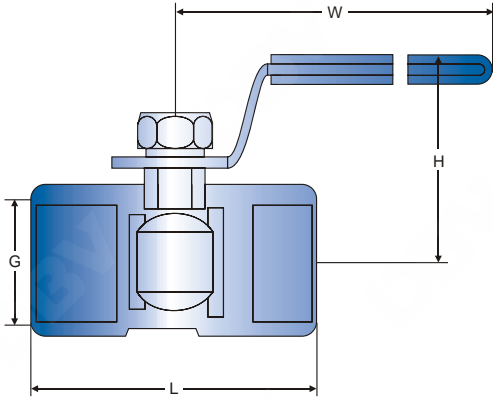

1000WOG DIMENSION

SIZE (in)	d	L	H	W	W.T (kg)
1/4	4.2	40	22	80	0.10
3/8	6	45	26	80	0.115
1/2	8	57	31	88	0.175
3/4	12	60	34	88	0.250
1	15	72	38	105	0.400
1-1/4	19	79	43	105	0.600
1-1/2	24	85	50	124	0.850
2	32	101	57	124	0.900

Unit: mm

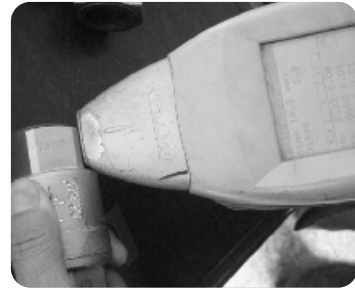
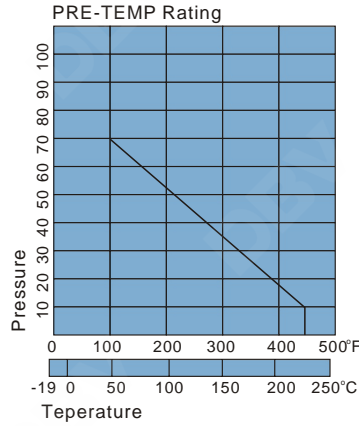

ONE PIECE FORGED BALL VALVE

- Investment Forged One Piece Hex. Uni-body, Reduced Bore
- Free Floating Ball, Fire Safe, Blow-out Proof Stem
- Anti-static Device, Cavity Relieving Seats
- Optional Locking Device & ISO5211 Mounting Pad
- Designed to ASME B16.34

Face to Face	DBV Standard
Threaded Ends	Rc to BS21, NPT to ASME B1.20.1
Socketed Ends	ASME B16.11
Class	ASME CL800/2000Psi

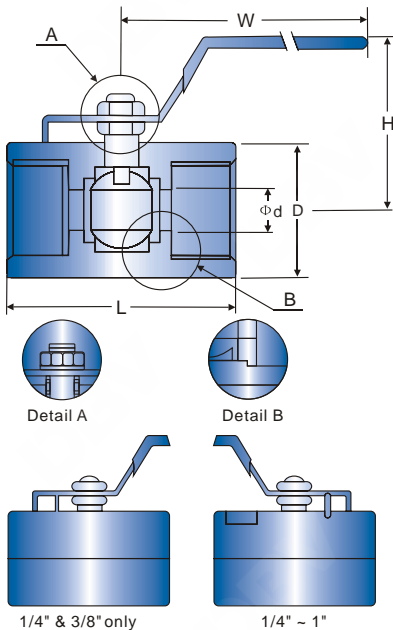

CLASS 800/2000WOG DIMENSION

SIZE (in)	Φd	D	L	H	W	W.T (kg)
1/4	5.0	21	43	34	70	0.11
3/8	7.0	25	47	37	70	0.18
1/2	9.0	31	62.5	60	120	0.34
3/4	12.5	36	70	64	120	0.54
1	16.0	46	86	66	123	0.95
1-1/4	20.0	55	94	78	145	1.40
1-1/2	24.5	61	102	84	150	1.70
2	32.0	75	115	91	150	2.78

Unit: mm

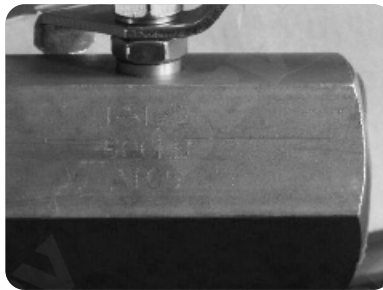

TWO PIECE CASTED BALL VALVE

- Investment Casting Two Piece Split Body, Full Port
- Free Floating Ball, Fire Safe, Blow-out Proof Stem
- Anti-static Device, Cavity Relieving Seats
- Optional Locking Device & ISO5211 Mounting Pad
- Designed to ASME B16.34

Face to Face	DBV Standard
Threaded Ends	Rc to BS21, NPT to ASME B1.20.1
Socketed Ends	ASME B16.11
Class	1000Psi

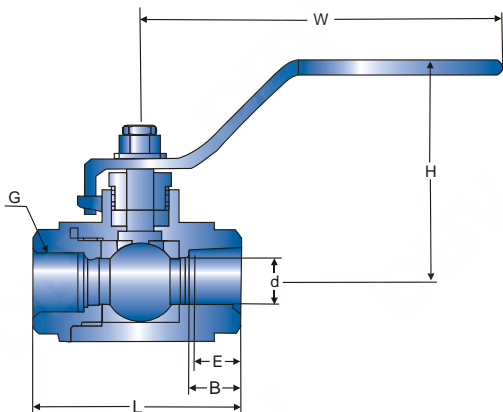

1000WOG DIMENSION

SIZE (in)	d	L	W	H	W.T (kg)	Unit: mm
1/4	10	55	95	42	0.2	
3/8	10	55	95	42	0.2	
1/2	15	65	108	51	0.35	
3/4	20	75	115	58	0.5	
1	25	85	135	77	0.75	
1-1/4	32	102	150	83	1.3	
1-1/2	38	108	175	97	2.0	
2	50	124	190	106	3.3	
2-1/2	65	163	220	122	6.1	
3	80	185	250	133	9.9	

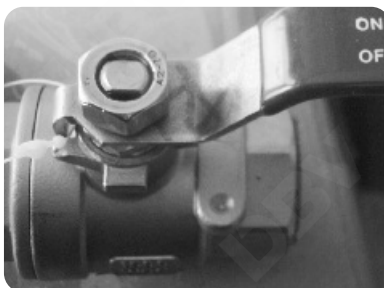

TWO PIECE FORGED BALL VALVE

- Investment Forged Two Piece Split body, Free Floating Ball
- Full Port or Reduced Bore, Fire Safe, Blow-out Proof Stem
- Anti-static Device, Cavity Relieving Seats
- Optional Locking Device & ISO5211 Mounting Pad
- Designed to ASME B16.34, BS5351

Face to Face	DBV Standard
Threaded Ends	Rc to BS21, NPT to ASME B1.20.1
Socketed Ends	ASME B16.11
Class	ASME CL1500/2500

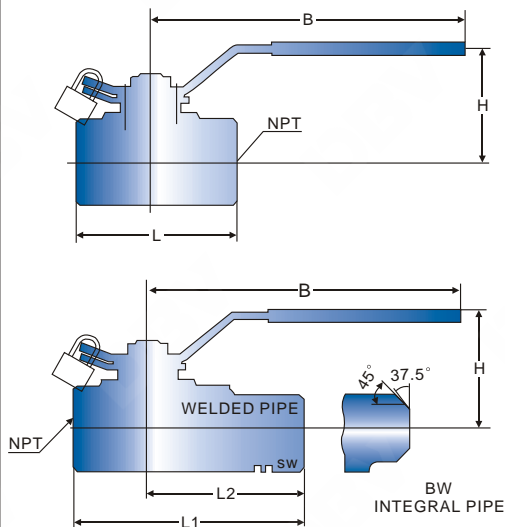

CLASS 1500/2500 DIMENSION

R.P(in)	1/4	1/2	3/4	1	1-1/4	1-1/2	2	2	Unit: mm
F.P(in)	3/8	1/2	3/4	1	1-1/4	1-1/2			
L1	70	70	80	95	115	125	135	155	
L2	121	121	121	130	136	140	148	160	
B	160	160	160	160	170	230	230	280	
H	60	60	60	65	85	105	105	125	
d	6	9	12.5	17	24	37	37	49	
W.T(kg)	1.2	0.9	1.3	2.2	3.5	6.5	6.5	11	

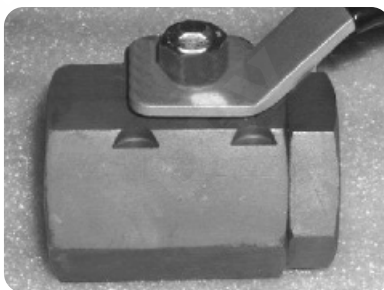

TWO PIECE FORGED BALL VALVE

- Investment Forged Two Piece Split body, Free Floating Ball
- Full Port or Reduced Bore, Fire Safe, Blow-out Proof Stem
- Anti-static Device, Cavity Relieving Seats
- Optional Locking Device & ISO5211 Mounting Pad
- Designed to ASME B16.34, BS5351

Face to Face	DBV Standard
Threaded Ends	Rc to BS21, NPT to ASME B1.20.1
Socketed Ends	ASME B16.11
Class	ASME CL1500/2500

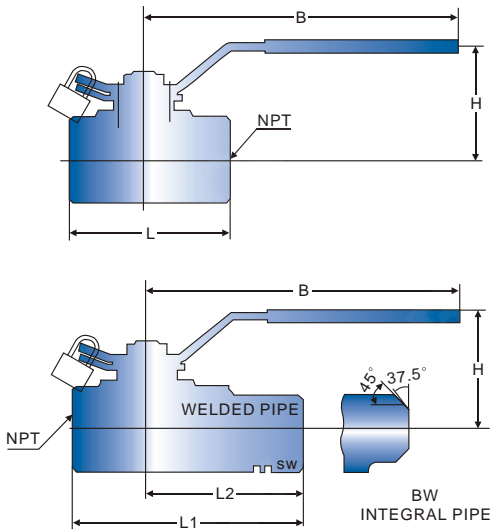

CLASS 1500 DIMENSION

SIZE (in)	1/4	3/8	1/2	3/4	1	1 1/4	1 1/2	2	Unit mm
L1	80	80	95	115	125	135	155	155	
L2	121	121	130	136	140	148	160	175	
B	160	160	160	170	230	230	280	280	
H	60	60	65	85	105	105	125		
d	6	9	13	19	25	32	38	49	
W.T(kg)	1.2	1.5	2.5	3.7	5.8		11.5	13.7	

CLASS 2500 DIMENSION

SIZE (in)	1/2	3/4	1	1 1/2	2	Unit mm
L1	125	135	155	155		
L2	136	140	148	175		
B	230	230	280	280	130	
H	90	110	125			
d	13	19	25	38	42	
W.T(kg)	2.7	4.1	6.3	12	15	

THREE PIECE FORGED BALL VALVE

- Investment Casting Three Piece Body, Free Floating Ball
- Full Port or Reduced Bore, Fire Safe, Blow-out Proof Stem
- Anti-static Device, Cavity Relieving Seats
- Optional Locking Device & ISO5211 Mounting Pad
- Designed to ASME B16.34

Face to Face	DBV Standard
Threaded Ends	Rc to BS21, NPT to ASME B1.20.1
Socketed Ends	ASME B16.11
Class	1000/2000/3000CWP

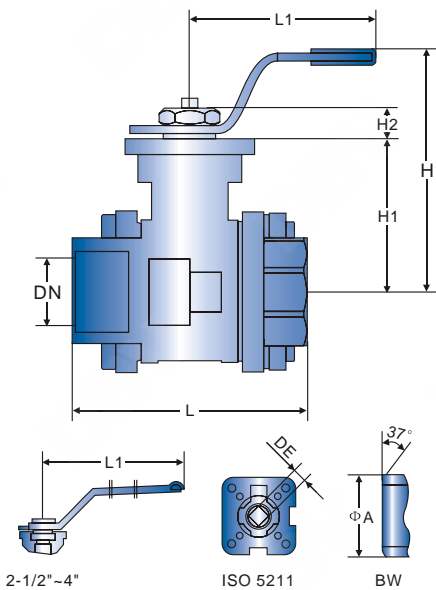

1000/2000/3000CWP DIMENSION

SIZE (in)	A	L	L1	E	H	H1	H2	ISO5211	Unit mm
3/8"	18	60	120	9	63	32	32	F03/F04	
1/2"	22.5	73.5	120	9	70	40	40	F03/F04	
3/4"	27	80	137	11	80	50	50	F04/F05	
1"	34.5	90	137	11	90	57	57	F04/F05	
1-1/4"	43	110	187	11	95	61	61	F04/F05	
1-1/2"	49	120	187	11	105	76	76	F04/F05	
2"	62	140	187	14	112	84	84	F05/F07	
2-1/2"	76.5	185	315	17	174	100	100	F07/F10	
3"	92	206	315	17	185	111	111	F07/F10	
4"	115.5	240	315	19	205	130	130	F07/F10	

PRESSURE-TEMPERATURE RATING 3/8"-4"

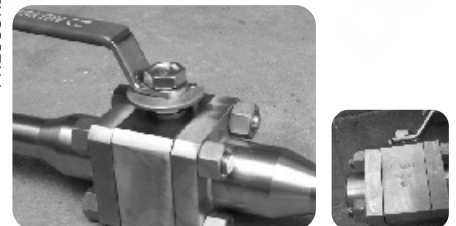
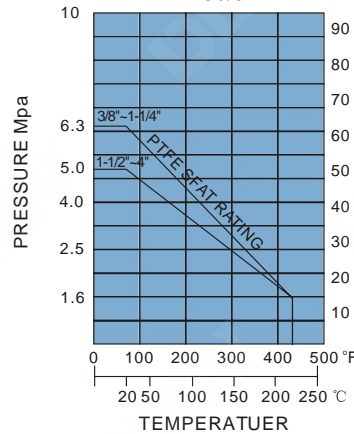

THREE PIECE FORGED BALL VALVE

- Investment Forged Three Piece Body, Free Floating Ball
- Full Port or Reduced Bore, Fire Safe, Blow-out Proof Stem
- Anti-static Device, Cavity Relieving Seats
- Optional Locking Device & ISO5211 Mounting Pad
- Designed to ASME B16.34, BS5351

Face to Face	DBV Standard
Threaded Ends	Rc to BS21, NPT to ASME B1.20.1
Socketed Ends	ASME B16.11
Class	ASME CL800/1500/2500

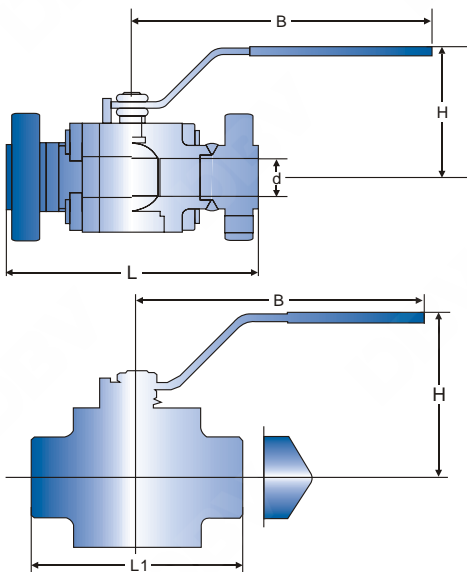

CLASS 800 DIMENSION

SIZE (in)	1/4	3/8	1/2	3/4	1	1-1/4	1-1/2	2	Unit mm
L1	92	92	92	111	127	140	152	152	
B	108	108	108	146	178	178	200	200	
H	51	51	51	108	81	85	105	105	
d	6	9	13	18	23	28	35	49	
W.T(kg)	2.5	2.4	2.3	3.4	5.4	6.4	11	13	

CLASS 1500 DIMENSION

SIZE (in)	1/4	3/8	1/2	3/4	1	1-1/4	1-1/2	2	Unit mm
L1	92	92	92	111	127	140	152	152	
B	108	108	108	146	178	178	200	200	
H	51	51	51	108	81	85	105	105	
d	6	9	13	19	25	32	38	49	
W.T(kg)	2.5	2.4	2.5	3.7	5.8	6.8	11.5	13.7	

CLASS 2500 DIMENSION

SIZE (in)	1/2	3/4	1	1-1/2	Unit mm
L	110	125	135	160	
B	170	230	230	310	
H	95	110	125		
d	13	19	25	38	
W.T(kg)	2.7	4.1	6.3	12	

THREE PIECE FORGED BALL VALVE

- Investment Forged Three Piece Body, Free Floating Ball
- Full Port or Reduced Bore, Fire Safe, Blow-out Proof Stem
- Anti-static Device, Cavity Relieving Seats
- Optional Locking Device & ISO5211 Mounting Pad
- Designed to ASME B16.34, BS5351

Face to Face	DBV Standard
Threaded Ends	Rc to BS21, NPT to ASME B1.20.1
Socketed Ends	ASME B16.11
Flanged Ends	ASME B16.5
Class	ASME CL1500-CL2500

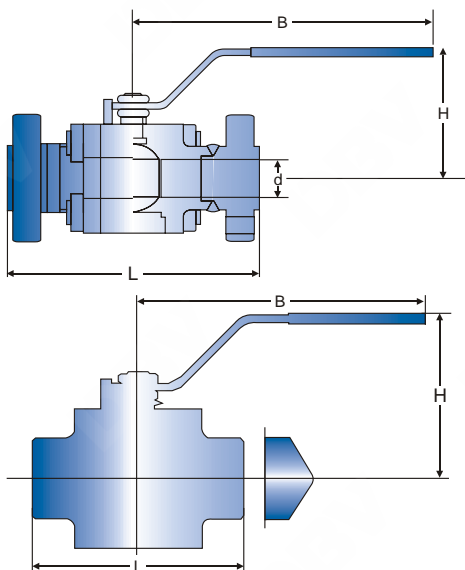

CLASS 1500 DIMENSION

SIZE (in)	1/2	3/4	1	1-1/4	1-1/2	2	Unit mm
L	216	229	256	279	305	368	
B	230	230	350	280	400	400	
H	75	85	85	105	110	130	
d	13	19	25	32	38	49	
W.T(kg)	2.5	5.8	5.8	6.8	12	13.7	

CLASS 2500 DIMENSION

SIZE (in)	1/2	3/4	1	1-1/4	1-1/2	2	Unit mm
L	264	273	308	349	400	451	
B	280	280	95	350	110	400	
H	75	85	95	105	38	130	
d	13	19	25	32	11.5	42	
W.T(kg)	2.7	6.3	6.3	6.8		15	



THREE PIECE FLANGED BALL VALVE

- Investment Casting Three Piece Body, Free Floating Ball
- Full Port or Reduced Bore, Fire Safe, Blow-out Proof Stem
- Anti-static Device, Cavity Relieving Seats
- Optional Locking Device & ISO5211 Mounting Pad
- Designed to DIN3357, BS5351

Face to Face	DBV Standard
Flanged Ends	ASME B16.5
Butt Weld	ASME B16.25
Class	PN16/PN25/PN40

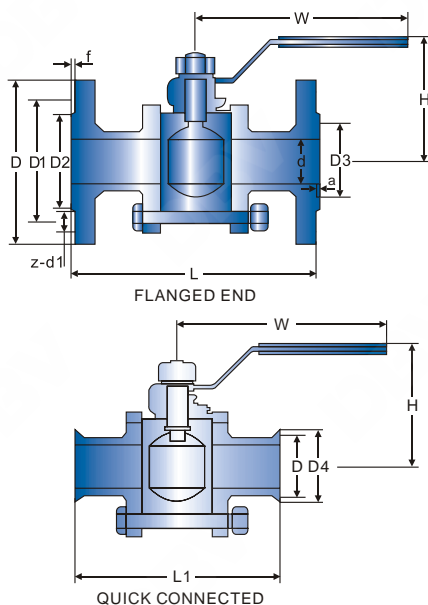

PN16/25/40 DIMENSION

SIZE (DN)	d	L	H	D	FLANGED END		f	PN4.0 a	Unit mm
					D1	D2			
15	15	130	77	95	65	45	2	4	
20	20	150	77	105	75	55	2	4	
25	25	160	88	115	85	65	2	4	
32	32	180	113	135	100	78	2	4	
40	40	200	132	145	112	85	3	4	
50	50	230	142	160	125	100	3	4	
65	65	290	173	180	145	120	3	4	
80	80	310	182	190	160	135	3	4	
100	100	350	250	215/230	180/190	122/162	3	4.5	

PN4.0 Z FLANGED END QUICK CONNECTED

SIZE (DN)	PN4.0 D3	Z	FLANGED END		QUICK CONNECTED			Unit mm
			d1	W	D	D4	L1	
15	40	4	14	130	43.5	50.5	108	
20	51	4	14	130	43.5	50.5	130	
25	58	4	14	130	43.5	50.5	138	
32	66	4	18	180	43.5	50.5	152	
40	76	4	18	230	56.5	64	166	
50	88	4	18	400	56.5	64	198	
65	110	4/8	18	400	83.5	91	230	
80	121	4/8	18	640	96	106	249	
100	150	4/8	18/23	1100	-	-	-	

THREE PIECE HIGH PRESSURE BALL VALVE

- Investment Forged Three Piece Body, Free Floating Ball
- Full Port or Reduced Bore, Fire Safe, Blow-out Proof Stem
- Anti-static Device, Cavity Relieving Seats
- Optional Locking Device & ISO5211 Mounting Pad
- Designed to ASME B16.34, BS5351

Face to Face	DBV Standard
Threaded Ends	Rc to BS21, NPT to ASME B1.20.1
Socketed Ends	ASME B16.11
Flanged Ends	ASME B16.5
Class	PN160/PN320

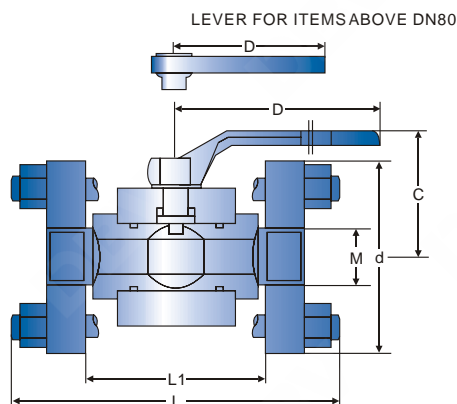

PN160/PN320 DIMENSION

SIZE (DN)	d	M	L	L1	C	D	Unit mm
15	100	33X2	160	70	62	130	
20	110	33X2	170	81	75	230	
25	115	42X2	195	95	80	230	
32	150	48X2	220	110	96	300	
40	170	64X3	260	120	111	400	
50	200	80X3	310	140	128	580	
65	225	100X3	345	150	180	580	
80	270	125X4	355	160	200	700	
100	320	155X4	440	188	245	1100	

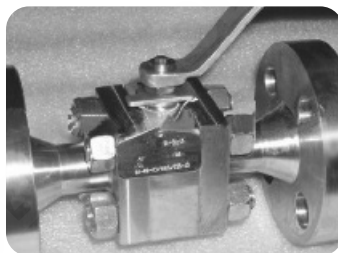

JACKETED BALL VALVE

- One Piece Uni-body, FullPort or Reduced Bore
- Floating Ball, Fire Safe, Blow-out Proof Stem
- Anti-static Device, Cavity Relieving Seats
- NACE MR-01-75, Optional Locking Device
- Designed to ASME B16.34

Face to Face	DBV Standard
End Flange	ASME B16.5
Buttweld	ASME B16.25
Class	PN16

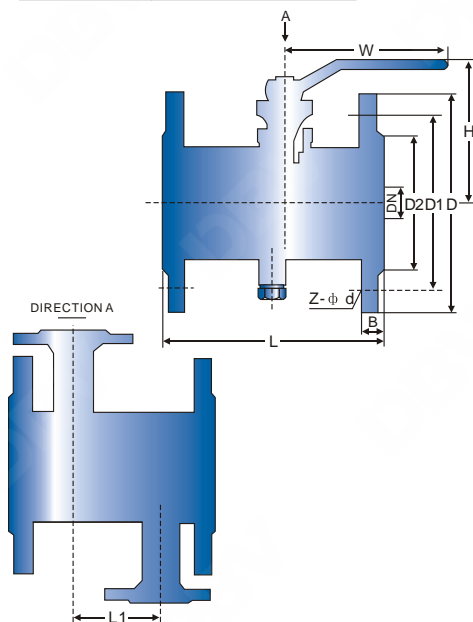

PN16 DIMENSION

SIZE (DN)	L	L1	D	D1	D2	B	Z-φ d	H	W	WT(kg) Unit:mm
15	108	45	95	65	45	14	4-φ 14	95	160	2.5
20	117	55	105	75	55	14	4-φ 14	101	160	3
25	127	65	115	85	65	14	4-φ 14	106	160	5
32	140	78	135	100	78	16	4-φ 18	112	230	6
40	165	85	145	110	85	16	4-φ 18	125	230	7
50	178	100	160	125	100	16	4-φ 18	135	230	10
65	191	120	180	145	120	18	4-φ 18	170	400	16
80	203	135	195	160	135	20	8-φ 18	193	400	19
100	229	155	215	180	155	20	8-φ 18	265	700	33
125	356	185	245	210	185	22	8-φ 18	310	700	48
150	394	210	280	240	210	24	8-φ 23	355	1100	62
200	457	265	335	295	265	26	12-φ 23	410	1500	93
250	533	320	405	355	320	30	12-φ 25	560	1500	120

WAFER BALL VALVE

- One Piece Uni-body, FullPort, Floating Ball
- Fire Safe, Blow-out Proof Stem
- Anti-static Device, Cavity Relieving Seats
- NACE MR-01-75, Optional Locking Device
- Designed to ASME B16.34

Face to Face	DBV Standard
End Flange	ASME B16.5
Buttweld	ASME B16.25
Class	PN16/PN25

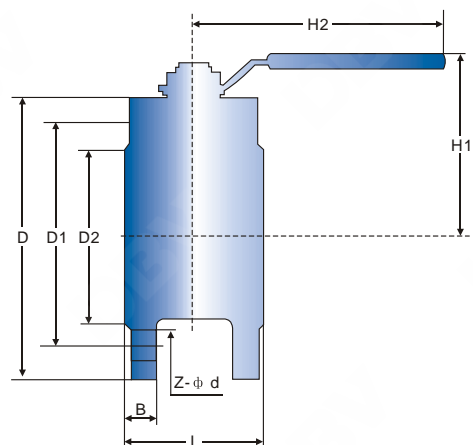

PN 16/25 DIMENSION

SIZE (DN)	L	D	D1	D2	B	Z-φ d	H1	H2	Unit:mm
20	38	105	75	55	16	4-14	70	130	
25	45	115	85	65	16	4-14	80	150	
32	55	140	100	78	18	4-18	86	150	
40	62	150	110	85	18	4-18	92	180	
50	72	165	125	100	20	4-18	102	180	
65	95	185	145	120	22	8-18	160	250	
80	120	200	160	135	22	8-18	172	300	
100	145	230	190	160	24	8-23	187	350	
125	200	270	220	188	28	8-26	200	650	
150	225	300	250	218	30	8-26	240	840	

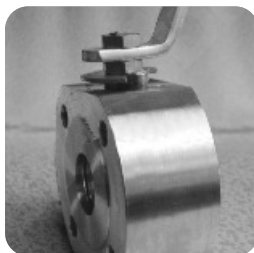

TWO PIECE TRUNNION BALL VALVES

The DBV two-piece split body trunnion mounted ball valve conforms to API 6D, ASME B16.34 and ASTM specifications. All seats are retained in metal holders which are spring-loaded against the ball for low pressure, fire safe sealing.

GENERAL DESIGN FEATURES

- Double block and bleed
- Anti blowout stem design
- O-rings plus fire safe packing prevents leakage
- corrosion resistant low friction bearings
- Inconel wave springs to provide upstream and downstream sealing
- Stainless Steel Sealant injection fittings for emergency stem or seat sealing
- Minimized torque required to open and close valve
- Antistatic grounding between ball, stem/trunnion and body
- Integral top works direct mounting pad



Before

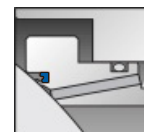

After

FIRE SAFE FUNCTION

In case of fire and seat construction damage, fire safe requirements are accomplished with automatic metal-to-metal positive sealing.

SELF RELIEVING SEAT DESIGN

Upstream Seat: The difference in the area ($D1$) times the line pressure creates a "piston effect" which forces the seat against the ball surface. Also the springs behind the seat add the force to the seat which keeps the seat in contact with the ball surface by providing the tight seal.

Downstream Seat: When the body cavity pressure exceeds the spring pressure, automatic pressure relief will occur by relieving the body cavity pressure past the downstream seat. This eliminates the need for the body relief valve.

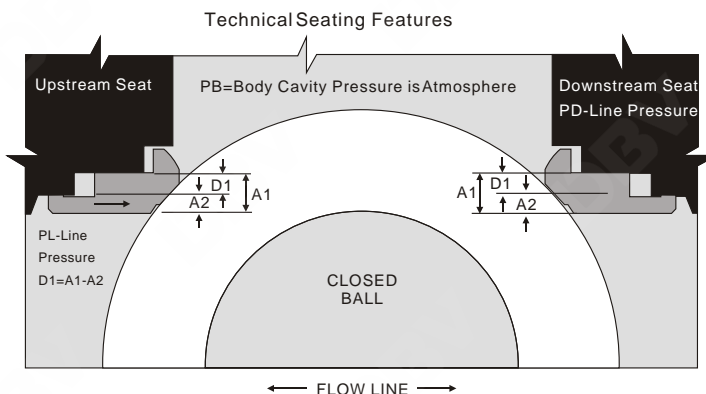
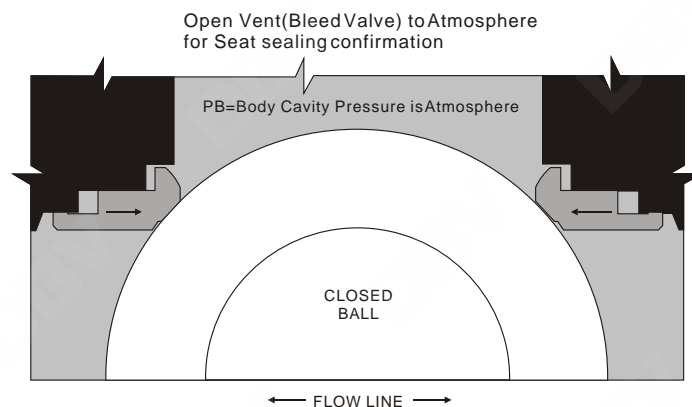

DOUBLE BLOCK AND BLEED

The double block and bleed condition is available in all seat design configurations. When the ball is in the closed position the body cavity pressure may be drained down to 'zero' by opening the bleed valve and draining the fluid by removing the drain plug. Each seat works independently assuring tight shut off seal against ball on the upstream and downstream side.

AVAILABILITY & MAXIMUM PRESSURE RATING, ASME B16.34 & API 6D

Class		Size (in.)													
		2FP	3RP	3FP	4RP	4FP	6RP	6RP	8RP	8FP	10RP	10FP	12RP	12FP	14RP
150	ASME B16.34	285	285	285	285	285	285	285	285	285	285	285	285	285	285
	API 6D	275	275	275	275	275	275	275	275	275	275	275	275	275	275
300	ASME B16.34	740	740	740	740	740	740	740	740	740	740	740	740	740	740
	API 6D	720	720	720	720	720	720	720	720	720	720	720	720	720	720

DESIGN FEATURES

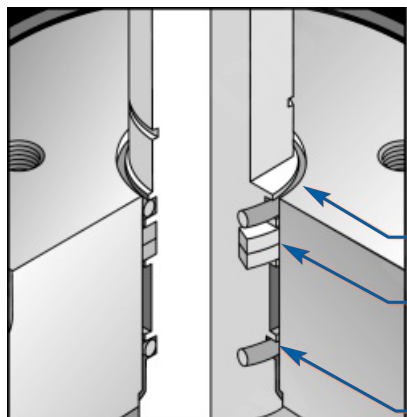

FIRE SAFE STANDARD DOUBLE SEAL

2"FP-12" Bore
Class 150&300

Weather Seal

Stem Packing
Braided Carbon Rope

Primary Stem Seal

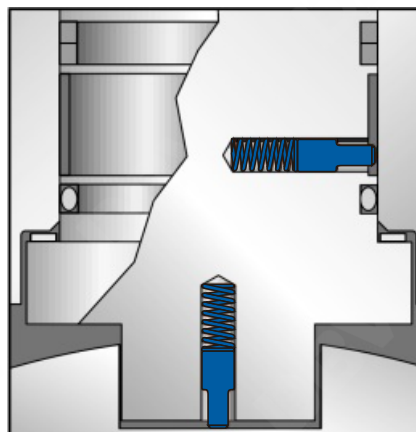

ANTISTATIC DEVICE*

A Stainless Steel grounding plunger between the body/stem and stem/ball permits electrical continuity.

*2"-4" bore Antistatic accomplished through trunnion bearing.

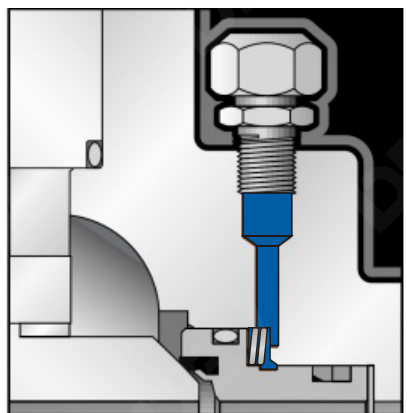

EMERGENCY SEAT SEAL

Special sealants may be injected into fittings that are located on the adapter flanges to restore sealing integrity if seat sealing surface is damaged.

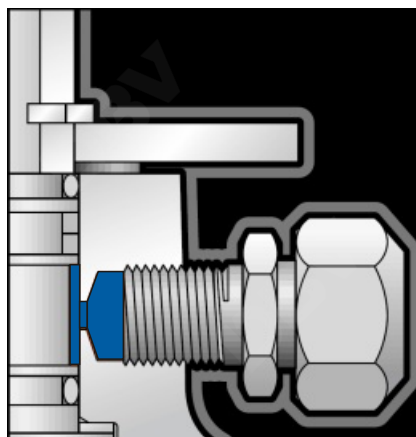

EMERGENCY SEALANT INJECTION SYSTEM

The Sealant Injection System Located on the body can be utilized in case of emergencies. O-ring damage, or if stem leakage occurs.

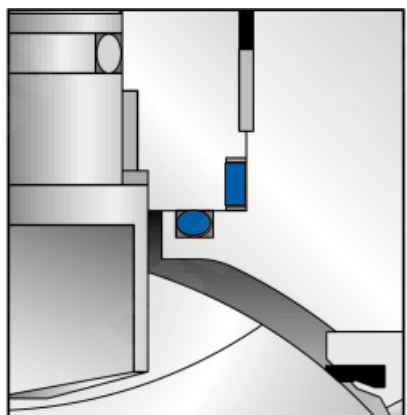

DOUBLE SEALED ENVELOPE CONNECTIONS 2"-4" BORE

A combination of an o-ring and Firesafe gasket ensures a positive seal.

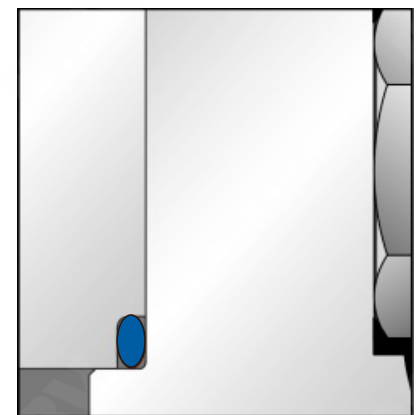

BODY/ADAPTER SEAL CONNECTION 6"-12" BORE

An o-ring on this connection ensures a positive seal.

HEAVY DUTY BEARINGS

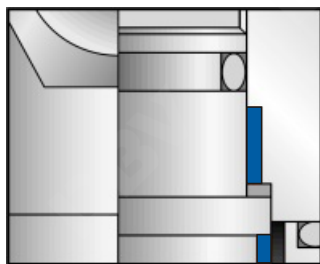

2"-4" bore.

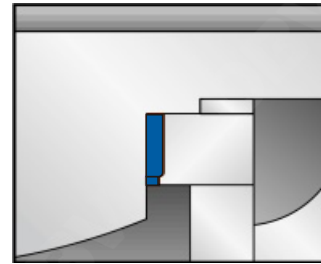
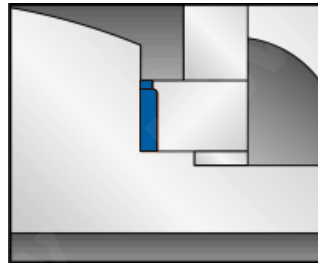
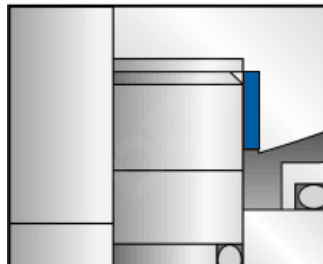

Teflon and glass liner with 316SS housing integral trunnion with trunnion blocks. 6"-12" bore.

Heavy duty bearings balance the pressure load on the ball by reducing friction between ball and seat resulting in smooth and easy operation of valve.

APPLICABLE STANDARDS

The following list contains the most important applicable standards for ball valves. DBV valves may be designed,

API-American Petroleum Institute

- Spec.6D Specification for pipeline valves,
- Spec.RP6F Recommended practice for firetesting of valves,
- Spec.6FA Specification for fire testing of valves,
- Std,598 Valve inspection and test.
- Std,607 Fire test for soft seated quarter-turn valves.

ASME/ANSI-American National Standard

- B 16.5 Steel pipe flanges and flanged fittings.
- B 16.10 Face-to-face and end-to-end dimensions of ferrous valves.
- B 16.25 Butt welding ends.
- B 16.34 Steel valves-Flanged and butt welding ends.
- B 31.3 Chemical plant and petroleum refinery piping
- B 31.4 Liquid petroleum transportation piping systems.
- B 31.8 Gas transmission and distribution piping systems.

British Standard

- BS 1503 Specification for steel forgings for pressure purposes.
- BS 1504 Specification for steel castings for pressure purposes.
- BS 1560 Steel pipe flanges and flanged fittings.
- BS 2080 Face-to-face, center-to-face, end-to-end, and center-to-end dimensions of flanged and butt-welding end steel valves for the petroleum, petrochemical and allied industries.
- BS 4504 Flanges and boltings for pipes, valves and fittings

Manufactured and tested in accordance with other international standards on request.

British Standard-cont

- BS 5146 Inspection and test of steel valves for the petroleum, petrochemical and allied industries.
- BS 5351 Steel ball valves for the petroleum, petrochemical and allied industries.
- BS 5750 Quality system.
- BS 6755 Testing of valves.

EC-European Community

CE Marked (P.E.D.97/23/EC.Cat.3)

ISO-International Organization for Standardization

ISO 9001:2000 Quality systems-Model for quality assurance in design/development, production, installation and servicing.

MSS-Manufacturers Standardization Society

- SP 6 Standard finishes for contact faces of pipe flanges and connecting-end flanges of valves and fittings.
- SP 25 Standard marking system for valves, fittings, flanges and unions.
- SP 55 Quality standard for steel castings-visual method.

NACE-National Association of Corrosion Engineers

MR 0175 Sulfide stress cracking resistant metallic materials for oil field equipment.

PART CONFIGURATION

- | | | | |
|---|---|---|--|
| End Connection | <ul style="list-style-type: none"> ● FLANGE ● WELD | Seat Insert | <ul style="list-style-type: none"> ● Teflon ● PEEK |
| NACE Conformance Body/Bolting Material (Finish) | <ul style="list-style-type: none"> ● NACE III/Cl.II Boting ● CS/B7 ● CS/B7 (Cadmium) ● CS/B7 (Zinc) | <ul style="list-style-type: none"> ● NACE II/Cl.II Boting ● CS/B7M (Black) ● CS/B7M (Cadmium) ● CS/B7M (Zinc) | <ul style="list-style-type: none"> ● Viton ● EPDM ● NBR |
| Trim & Drain | <ul style="list-style-type: none"> ● 316SS ● CS (3 milENP) ● SS w/Drain ● CS (3 milENP) w/Drain | Actuation | <ul style="list-style-type: none"> ● Handle (2"-8" only) ● Gear Operator ● Handle w/Locking Device (2"-8" only) ● Gear Operator w/Locking Device ● Bare Stem ● For Actuation |

BUTT WELD END SCHEDULE

Pipe Description	Nominal Pipe Size (in.) ● Schedule Code						
	2	3	4	6	8	10	12
Outside Dia.(in)	2.375	3.500	4.500	6.625	8.625	10.750	12.750
(STD) Standard	-	-	.237	.280	.322	.365	.375
Schedule 40	.154	.216	.237	.280	.322	.364	.406
Schedule 60	-	-	-	-	.406	.500	.562
XS	.218	.300	.337	.432	.500	.500	.500
Schedule 80	.218	.300	.337	.432	.500	.593	.687
Schedule 120	-	-	.438	.562	.718	.843	1.000
Schedule 160	.343	.438	.531	.718	.906	1.125	1.312
XXS	.436	.600	.674	.864	.875	1.000	1.000

Consult factory for other wall thicknesses.

● COMPONENT PARTS ● 2" FP-6"RP

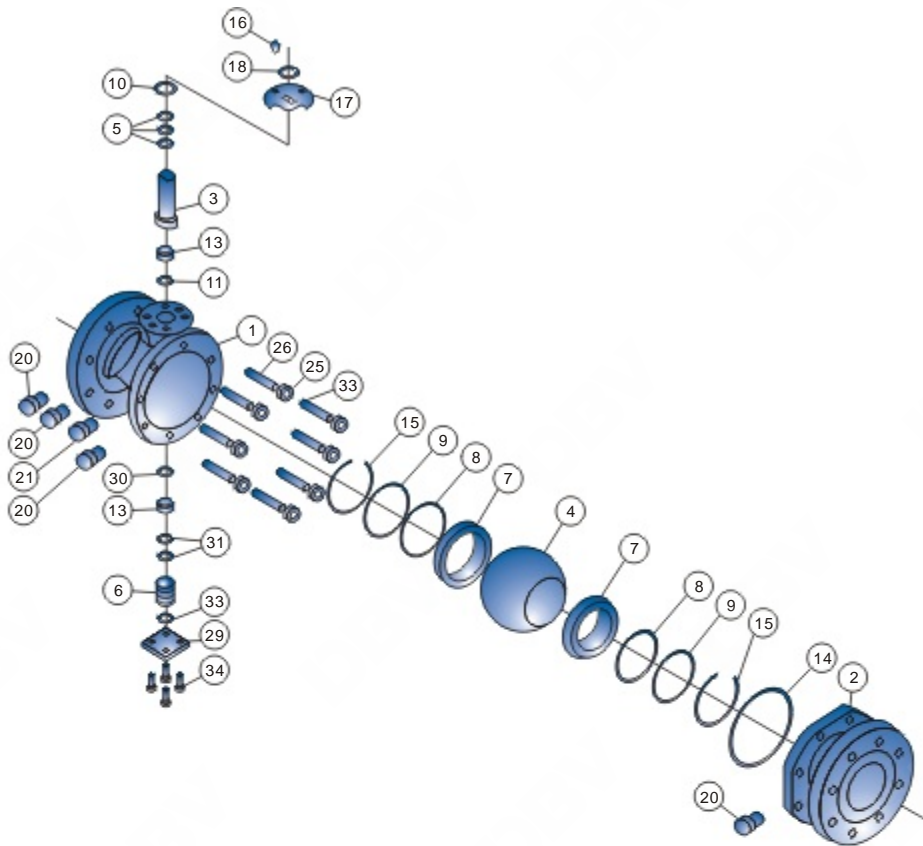

PARTS LIST

Part No	Description
1	Body
2	Adapter
3	Stem Assembly
4	Ball
5	Stem Seal
7	Seat
8	Seat O-Ring
9	Seat Sub Seal
10	Stem Bearing
11	Thrust Bearing
12	Trunnion Support
13	Trunnion Bearing
14	Body Seal
15	Wave Spring
16	Stop Screw
17	Stop Plate
18	Retainer
20	Injection Fitting
21	Bleed Valve
25	Hex Nut
26	Stud

● COMPONENT PARTS ● 6" FP-14"RP*

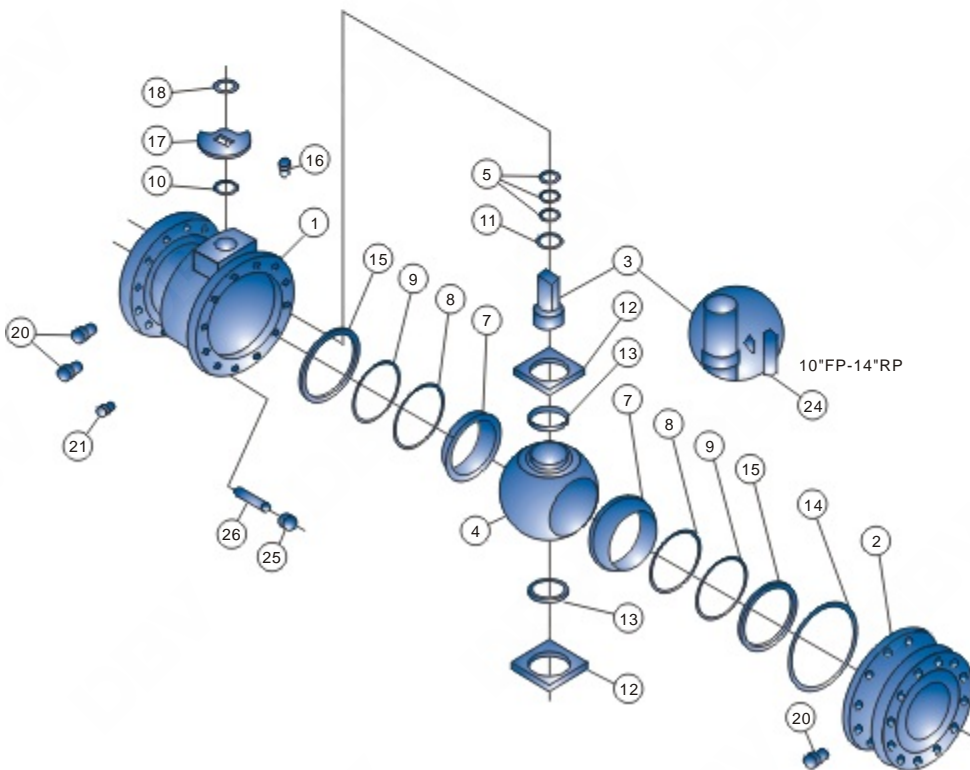

PARTS LIST

Part No	Description
1	Body
2	Adapter
3	Stem Assembly
4	Ball
5	Stem Seal
7	Seat
8	Seat O-Ring
9	Seat Sub Seal
10	Stem Bearing
11	Thrust Bearing
12	Trunnion Support
13	Trunnion Bearing
14	Body Seal
15	Wave Spring
16	Stop Screw
17	Stop Plate
18	Retainer
20	Injection Fitting
21	Bleed Valve
24	Key. 10"FP thru 12"FP only
25	Hex Nut
26	Stud

SPLIT BODY TRUNNION MOUNTED BALL VALVE

- Two Piece Split Body, Full Port or Reduced Bore
- Trunnion Mounted, Fire Safe, Blow-out Proof Stem
- Anti-static Device, Cavity Relieving Seats
- NACE MR-01-75, Optional Locking Device

• Designed to ASME B16.34, API 6D

Face to Face	API 6D
End Flange	ASME B16.5
Buttweld	ASME B16.25
Class	ASME CL150

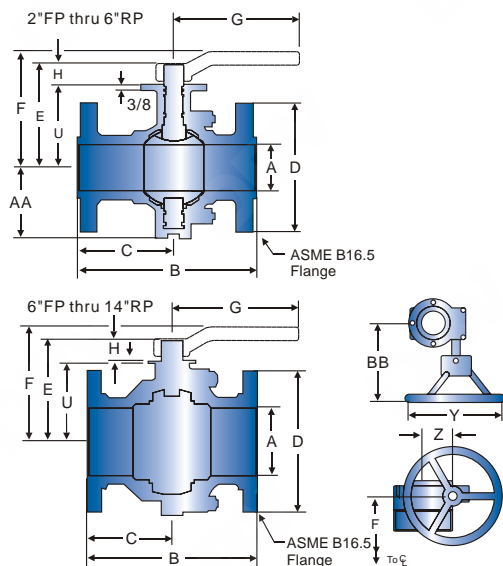

CLASS 150 DIMENSION

SIZE Valve w/ (in.) Only	G.O	A	B	C	D	E	F	G	H	U	Y	Z	AA	BB	Unit:inch	
W.T.(lbs.)		Top of CL of Handle H/Whl.														
2X2	31	43	2	7	3-1/8	6	4-15/16	6-7/8	5	8-1/2	1-1/16	3-7/8	8	2-3/4	3-9/16	7-3/16
3X2	33	46	2	8	4	7-1/2	4-15/16	6-7/8	5	8-1/2	1-1/16	3-7/8	8	2-3/4	3-9/16	7-3/16
3X3	52	65	3	8	3-7/8	7-1/2	6-5/8	8-1/4	6-1/2	15	1-1/4	5-3/8	8	2-3/4	4-1/2	7-3/16
4X3	60	70	3	9	4-1/2	9	6-5/8	8-1/4	6-1/2	15	1-1/4	5-3/8	8	2-3/4	4-1/2	7-3/16
4X4	78	91	4	9	4-1/2	9	7-7/16	9	7-5/16	15	1-1/4	6-3/16	8	2-3/4	4-1/2	7-3/16
6X4	110	123	4	15-1/2	5-1/4	11	7-7/16	9	7-5/16	15	1-1/4	6-3/16	8	2-3/4	5-1/4	7-3/16
6X6	204	234	6	15-1/2	7-3/4	11	9-1/2	10-13/16	9-1/4	48	2-3/32	7	12	2-1/2	5-1/4	9-1/4
8X6	271	301	6	18	9	13-1/2	9-1/2	10-13/16	9-1/4	48	2-3/32	7	12	2-1/2	-	9-1/4
8X8	365	429	8	18	9	13-1/2	11-9/16	12-19/32	10-3/8	48-5/16	2-3/8	8-3/4	18	3-1/2	-	11-15/16
10X8	456	520	8	21	10-1/2	16	11-9/16	12-19/32	10-3/8	48-5/16	2-3/8	8-3/4	18	3-1/2	-	11-15/16
10X10	528	605	10	21	10-1/2	16	14-5/16	-	13-3/8	-	3-3/16	11-1/4	24	4-5/8	-	14-5/8
12X10	648	725	10	24	12	19	14-5/16	-	13-3/8	-	3-3/16	11-1/4	24	4-5/8	-	14-5/8
12X12	794	899	12	24	12	19	15-11/16	-	14-3/4	-	3-3/16	12-5/8	24	4-5/8	-	14-5/8
14X12	944	1049	12	27	13-1/2	21	17-11/16	-	16-1/4	-	3-3/16	14-5/8	36	4-5/8	-	17-3/4

SPLIT BODY TRUNNION MOUNTED BALL VALVE

- Two Piece Split Body, Full Port or Reduced Bore
- Trunnion Mounted, Fire Safe, Blow-out Proof Stem
- Anti-static Device, Cavity Relieving Seats
- NA CE MR-01-75, Optional Locking Device

• Designed to ASME B16.34, API 6D

Face to Face	API 6D
End Flange	ASME B16.5
Buttweld	ASME B16.25
Class	ASME CL300

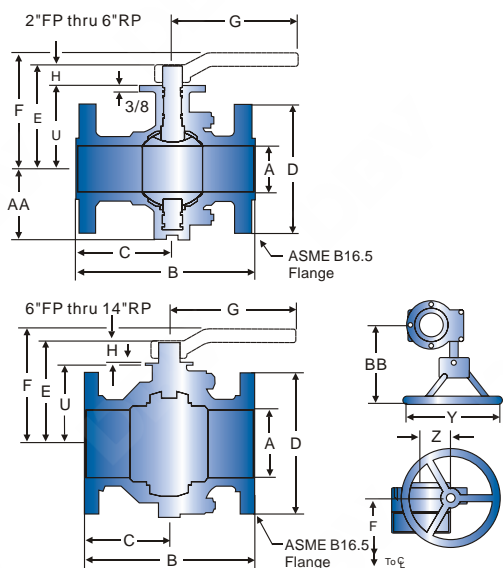

CLASS 300 DIMENSION

SIZE Valve w/ (in.) Only	G.O	A	B	C	D	E	F	G	H	U	Y	Z	AA	BB	Unit:inch	
Wt.(lbs.)		Top of CL of Handle H/Whl.														
2X2	35	48	2	8-1/2	4-1/4	6-1/2	4-15/16	6-7/8	5	8-1/2	1-1/16	3-7/8	8	2-3/4	3-9/16	7-3/16
3X2	42	55	2	11-1/8	5-9/16	8-1/4	4-15/16	6-7/8	5	8-1/2	1-1/16	3-7/8	8	2-3/4	3-9/16	7-3/16
3X3	63	76	3	11-1/8	6	8-1/4	6-5/8	8-1/4	6-1/2	15	1-1/4	5-3/8	8	2-3/4	4-1/2	7-3/16
4X3	83	96	3	12	6	10	6-5/8	8-1/4	6-1/2	15	1-1/4	5-3/8	8	2-3/4	4-1/2	7-3/16
4X4	114	127	4	12	6	10	7-7/16	9	7-5/16	15	1-1/4	6-3/16	8	2-3/4	4-1/2	7-3/16
6X4	160	173	4	15-7/8	7-15/16	12-1/2	7-7/16	9	7-5/16	15	1-1/4	6-3/16	8	2-3/4	5-1/4	7-3/16
6X6	282	312	6	15-7/8	7-15/16	12-1/2	9-1/2	10-13/16	9-1/4	48	2-3/32	7	14	2-1/2	5-1/4	9-3/8
8X6	352	382	6	19-3/4	9-7/8	15	9-1/2	10-13/16	9-1/4	48	2-3/32	7	14	2-1/2	-	9-3/8
8X8	481	545	8	19-3/4	9-7/8	15	11-9/16	12-19/32	10-3/8	48-5/16	2-3/8	8-3/4	18	3-1/2	-	11-15/16
10X8	597	661	8	22-3/8	11-3/16	17-1/2	11-9/16	12-19/32	10-3/8	48-5/16	2-3/8	8-3/4	18	3-1/2	-	11-15/16
10X10	735	840	10	22-3/8	11-3/16	17-1/2	14-5/16	-	13-3/8	-	3-3/16	11-1/4	24	4-5/8	-	14-5/8
12X10	904	1009	10	25-1/2	12-3/4	20-1/2	14-5/16	-	13-3/8	-	3-3/16	11-1/4	24	4-5/8	-	14-5/8
12X12	1083	1188	12	25-1/2	12-3/4	20-1/2	15-11/16	-	14-3/4	-	3-3/16	12-5/8	24	4-5/8	-	14-5/8
14X12	1233	1385	12	30	15	23	15-11/16	-	14-1/4	-	3-3/16	12-5/8	24	4-5/8	-	17-3/4

TOPWORKS & STEM TORQUE (IN.)

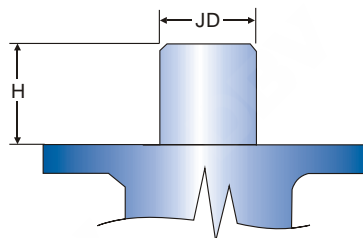
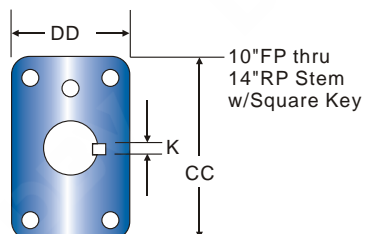
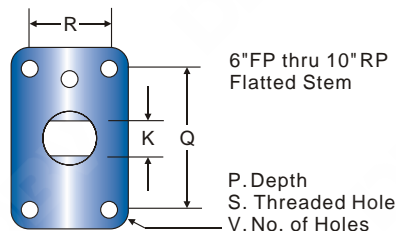
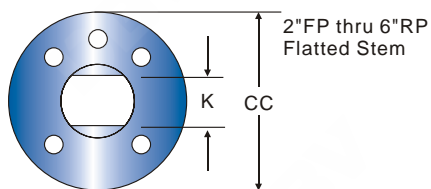

Valve SIZE (in.)	Pressure Class	H	JD Stem Dia.	K	P Hole Depth	Q	R	S Threaded Hole	V No. of Holes	CC	DD	Max. Stem Shear Torque Ft.-Lbs.	Break* Torque In.-Lbs.	Torque Expression See Notes 1,2,3 Below Chart
2	150	1-1/16	.873/.867	.558/.554	-	-	-	-	4	4-1/8	-	1634	351	.624*P+1728
2	300	1-1/16	.873/.867	.558/.554	-	-	-	-	8	4-1/8	-	1634	632	
3	150	1-1/4	1.246/1.240	.748/.744	-	-	-	-	4	4-1/8	-	4297	768	1.29*P+400
3	300	1-1/4	1.246/1.240	.748/.744	-	-	-	-	8	4-1/8	-	4297	1355	
4	150	1-1/4	1.246/1.240	.748/.744	-	-	-	-	8	4-1/8	-	4297	1178	1.44*P+768
4	300	1-1/4	1.246/1.240	.748/.744	-	-	-	-	8	4-1/8	-	4297	1834	
6	150	2-3/32	1.999/1.995	1.249/1.246	3/4	3-3/8	2	3/8-16	8	5-1/8	3-1/8	18.959	4968	4.8*P+3600
6	300	2-3/32	1.999/1.995	1.249/1.246	3/4	4-1/2	2-3/8	1/2-13	12	5-5/8	3-1/2	18.959	7152	
8	150	2-3/8	2.499/2.495	1.249/1.246	1	4-5/8	2-7/8	1/2-13	8	6-1/4	4-1/8	46.657	8714	11.04*P+5568
8	300	2-3/8	2.499/2.495	1.249/1.246	1	4-5/8	2-7/8	1/2-13	12	6-1/4	4-1/8	46.657	13.738	
10	150	3-3/16	2.874/2.871	3/4Sq.	1-1/8	6	3-1/2	5/8-11	12	7-1/2	5	68.121	15.157	19.07*P+9722
10	300	3-3/16	2.874/2.871	3/4Sq.	1-1/8	6	3-1/2	5/8-11	16	7-1/2	5	68.121	23.834	
12	150	3-3/16	2.874/2.871	3/4Sq.	1-1/8	6	3-1/2	5/8-11	12	7-1/2	5	68.121	20.811	28.90*P+12.574
12	300	3-3/16	2.874/2.871	3/4Sq.	1-1/8	6	3-1/2	5/8-11	16	7-1/2	5	68.121	33.960	

*Torque listed is calculated for "clean wet service" use 1.22 multiplier to this to calculate for "dry gas service".

Note: (1) Torques are actual and based on maximum differential low temperature service, without safety factors.
 (2) DBV recommends adding a 25% safety factor for pneumatic and 50% for electric actuators
 (3) Differential pressure "P" in torque expression is in PSI.

Pressure ratings according to API6D:
 Class 150 P=285 psi
 Class 300 P=740 psi



PRESSURE TEMPERATURE AND FLOW DATA

Ball Valve

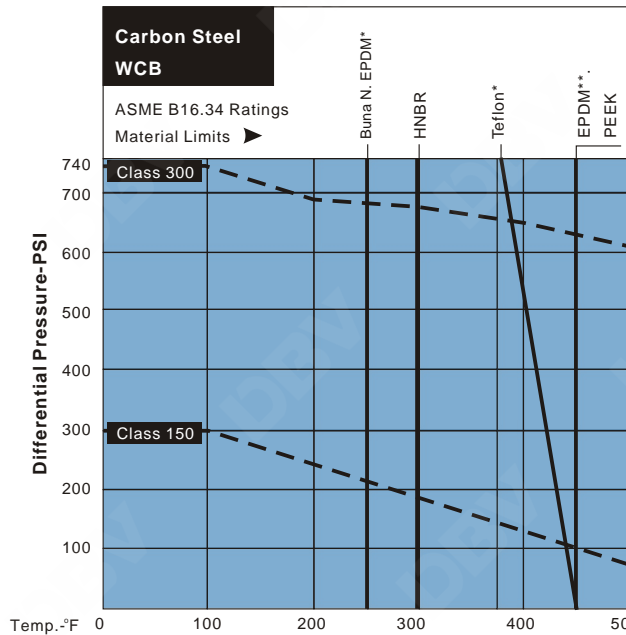
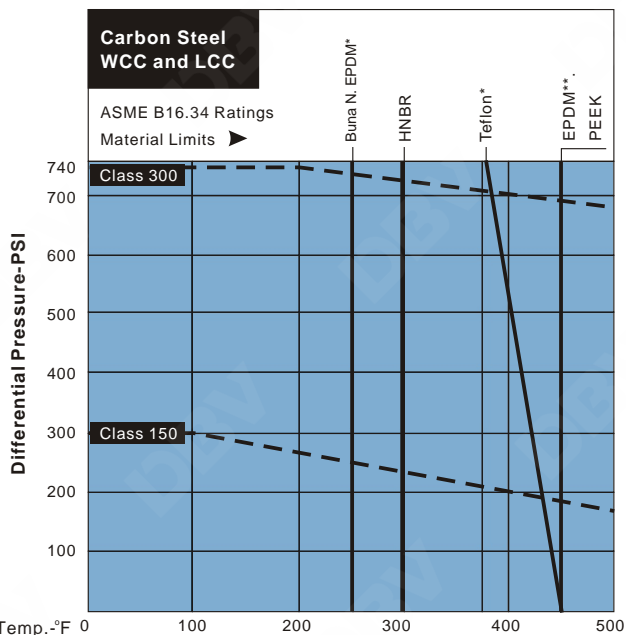

Pressure Temperature Chart Notes: Consult factory for service above 325° F
*For chemical service. ** For water and steam service only.

LOW TEMPERATURE LIMITS

Body Material	° F	° C	Seat Material	° F	° C
WCC	-20°	-28.9	Teflon	-50°	-45.6
LCC	-50°	-45.6	PEEK	-50°	-45.6
WCB	-20°	-28.9			
CF8M	-50°	-45.6			

Seat Material	° F	° C	Seat Material	° F	° C
Buna N	-30°	-34.4	Viton	+10°	-12.2
LowTempBunaN	-50°	-45.6	HNBR	-40°	-40°
Viton	-15°	26.1	EPDM	-50°	-45.6°

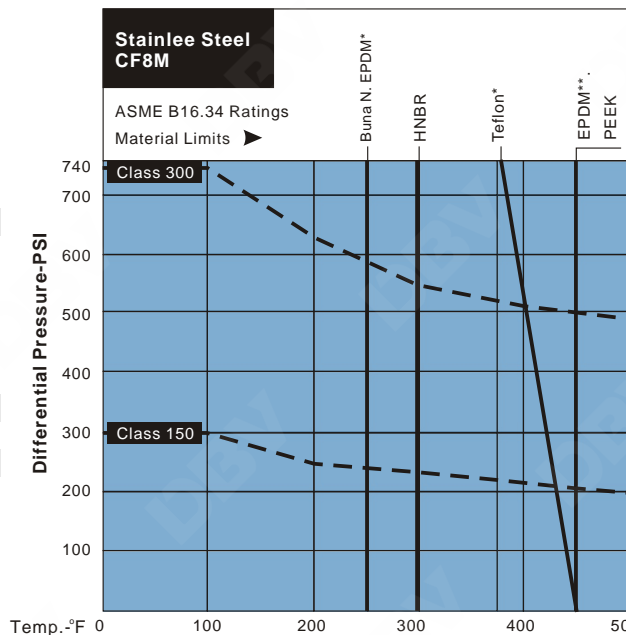

FLOW COEFFICIENT (CV)

Class	Size (in.)													
	2FP	3RP	3FP	4RP	4FP	6RP	6FP	8RP	8FP	10RP	10FP	12RP	12FP	14 RP
150	420	225	1050	600	2000	910	5470	2500	10.750	5000	17.775	8400	26.750	14.125
300	420	225	1050	600	2000	910	5100	2400	10.300	4825	16.300	8200	26.000	14.075

METHOD OF CALCULATING FLOW

The Flow Coefficient "Cv" of a valve is the flow rate of water (gallons/minute@60° F) through a fully opened valve, with a pressure drop of 1psi across the valve. To find the flow of liquid or gas through a valve from the Cv, use the following formulas:

LIQUID FLOW

QL = flow rate of liquid (gal./min.)
 ΔP = differential pressure across the valve (psi)
 G = specific gravity of liquid (for water, G=1)

$$QL = Cv \sqrt{\frac{\Delta P}{G}}$$

GAS FLOW

Qg = flow rate of gas (CFH at STP)
 P_2 = outlet pressure (psia)
 g = Specific gravity of gas (for air, g=1.000)

$$Qg = 61Cv \sqrt{\frac{P_2 \Delta P}{g}} \quad \text{For non-critical flow } \left\{ \frac{\Delta P}{P_2} < 1.0 \right\}$$

THREE PIECE TRUNNION MOUNTED BALL VALVES

A large trunnion design ensures central positioning under the highest working pressure. Independent floating spring loaded seat provide a tight seal even at low differential pressures. Service and maintenance is simplified with a bolted body design incorporating Double O-rings or a combination of O-rings and gaskets, Suitable for buried or above ground installation.

GENERAL DESIGN FEATURES

- Three-piece body design
- Double block and bleed
- Trunnion supported design reduces operating torque
- Antistatic device for grounding of the ball, stem and body
- Two sets of O-rings plus fire safe stem packing prevents leakage
- Corrosion resistant low friction bearings
- Inconel seat springs
- Sealant injection fittings for emergency system or seal sealing
- Direct mount top works pad for actuator or gear operator
- API Spec. 1, 6D, 6FA and 607
- ASME Section III Div. 1 - NCA 4000
- BS 5351, 5750 and 6755
- Locking device upon request
- NACE MR0175/ISO 15156
- Anti-blowout trunnion stem design

TECHNICAL SEATING FEATURES DOUBLE PISTON SEAT DESIGN

Upstream Seat: Line Pressure acting on the seat area (A1) does not equalize against the line pressure acting on the seat area (A2). The difference in the area (D1) times the line pressure creates a "piston effect" force which pushes the seat against the ball surface resulting in a tight effective seal.

Downstream Seat: When the body cavity pressure is greater than the downstream pressure, the body cavity pressure acts on the seal area (A4). The net pressure difference, acting over area (D2), pushes the downstream seat tightly against the ball creating a positive seal.

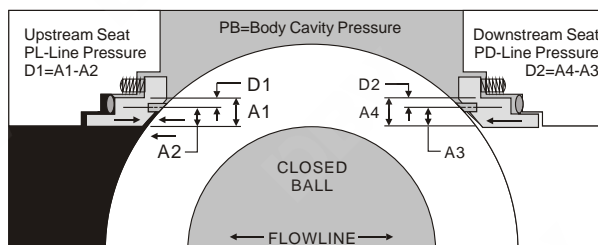
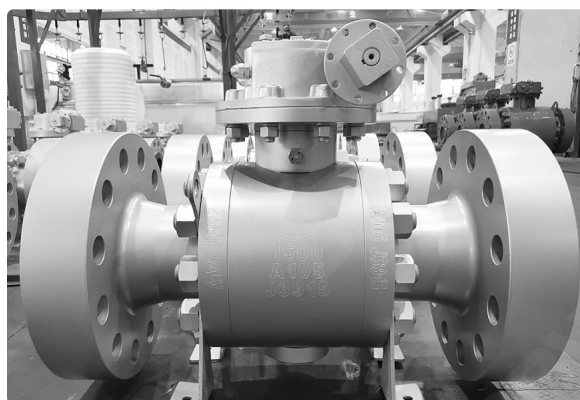

THE ULTIMATE BENEFIT OF USING THE "DOUBLE PISTON SEAT"

Design: In case of upstream seat leakage, the downstream seat maintains a pressure assisted tight shut off by sealing against the ball surface.

SELF RELIEVING SEAT DESIGN

Upstream Seat: The difference in the area (D1) times the line pressure creates a "piston effect" which forces the seat against the ball surface. Also the springs behind the seat add the force to the seat which keeps the seat in contact with the ball surface by providing the tight seal.

Downstream Seat: When the body cavity pressure exceeds the spring pressure, automatic pressure relief will occur by relieving the body cavity pressure past the downstream seat. This eliminates the need for the body relief valve.

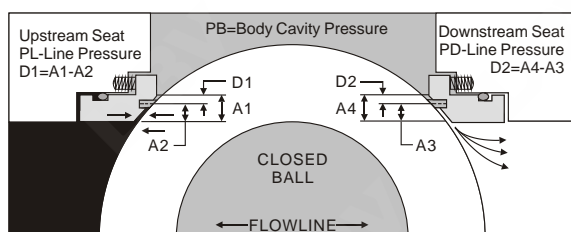

DOUBLE BLOCK AND BLEED

The double block and bleed condition is available in all seat design configurations. When the ball is in the closed position the body cavity pressure may be drained down to 'zero' by opening the bleed valve and draining the fluid by removing the drain plug. Each seat works independently assuring tight shut off seal against ball on the upstream and downstream side.

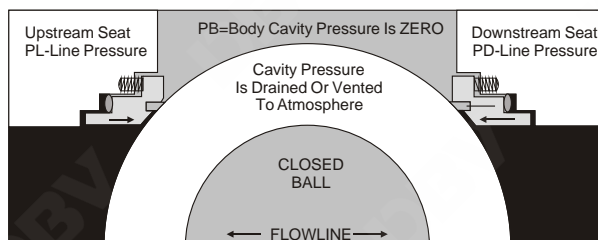

DESIGN FEATURES

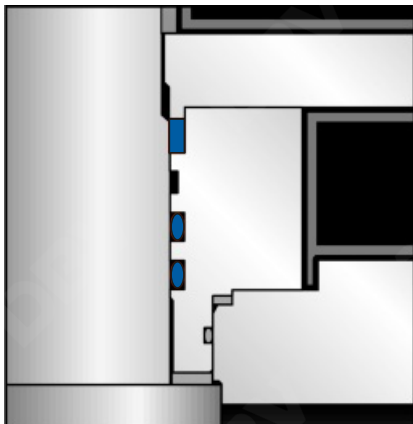

ANTI-BLOWOUT STEM DESIGN

Stem seal integrity is achieved by the use of three o-rings (or two o-rings and a graphite gasket). Upper o-ring (or graphite gasket) can be replaced with the valve in line and under pressure.

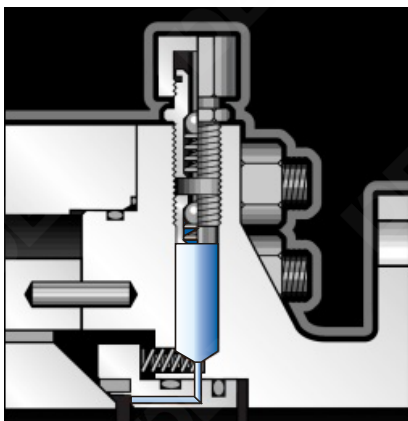

EMERGENCY SEALANT SEAT SEAL

Special sealants may be injected thru fittings that are located on the adapter flanges to restore sealing integrity if seat sealing surface is damaged. A second internal check valve provides backup to the fitting.

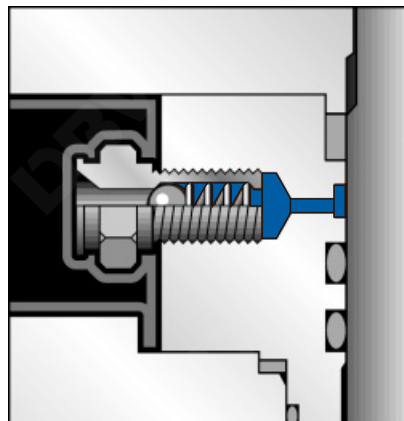

EMERGENCY SEALANT INJECTION SYSTEM

The Sealant Injection System located on the bonnet can be utilized in case of emergencies, o-ring damage, or if stem leakage occurs.

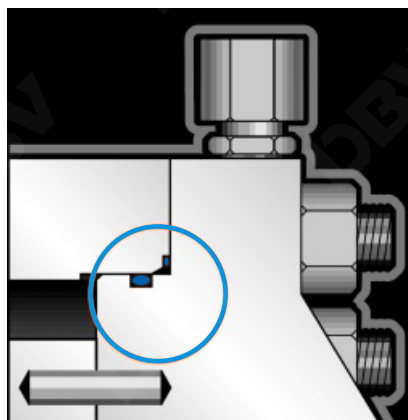

DOUBLE SEALED ENVELOPE CONNECTIONS

Double o-rings or a combination of an o-ring and firesafe gasket on body/adapter connections to ensure positive sealing. This makes These valves suitable for above or below ground service.

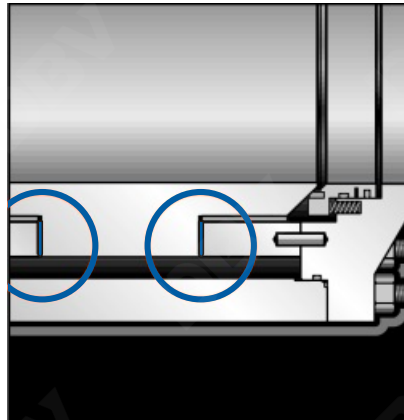

HEAVY DUTY BEARINGS

Trunnions are supported by heavy duty Teflon coated Steel Bearings. Thrust load on the ball is supported by large trunnions mounted within captured trunnion blocks, resulting in low operating torque and seat wear.

6"-12" Cl.900 & 1500
14"-24" Cl.150,300 & 600

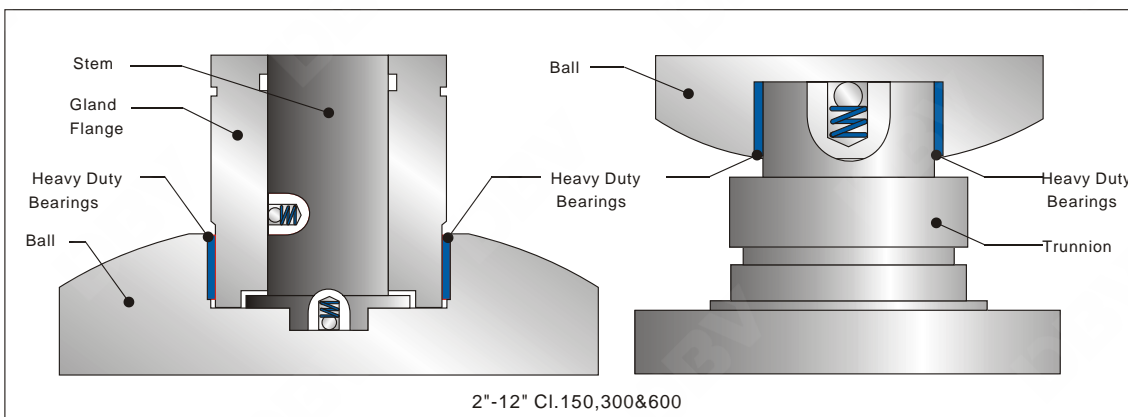

2"-12" Cl.150,300&600

ANTISTATIC DEVICE

A spring between the trunnion and the ball or between the stem and the gland plate permits electrical continuity between all valve components.

APPLICABLE STANDARDS

The following list contains the most important applicable standards for ball valves. DBV may be designed,

API-AMERICAN PETROLEUM INSTITUTE

- 6D Specification for pipeline valves,
- RP6F Recommended practice for fire testing of valves,
- 6FA Specification for fire testing of valves,
- 598 Valve inspection and test.
- 605 Large diameter carbon steel flanges.
- 607 Fire test for soft seated quarter-turn valves.

ASME/ANSI-AMERICAN NATIONAL STANDARD INSTITUTE

- B 16.5 Steel pipe flanges and flanged fittings.
- B 16.10 Face-to-face and end-to-end dimensions of ferrous valves.
- B 16.25 Butt welding ends.
- B 16.34 Steel valves-Flanged and butt welding ends.
- B 16.47 Steel Flanges.
- B 31.3 Chemical plant and petroleum refinery piping
- B 31.4 Liquid petroleum transportation piping systems.
- B 31.8 Gas transmission and distribution piping systems.
- B 46.1 Surface texture.

ASTM-American Society for Testing Materials

Consult factory for details.

ISO-International Organization for Standardization

ISO 9001:2000 Quality systems-Model for quality assurance in design/development, production, installation and servicing.

ISO 5211 Top works Mounting Dimensions

ISO 15156 For use INH₂S containing environments in oil and gas production

Manufactured and tested in accordance with other international standards on request.

British Standard

- BS 1503 Specification for steel forgings for pressure purposes.
- BS 1504 Specification for steel castings for pressure purposes.
- BS 1560 Steel pipe flanges and flanged fittings.
- BS 2080 Face-to-face, center-to-face, end-to-end, and center-to-end dimensions of flanged and butt-welding end steel valves for the petroleum, petrochemical and allied industries.
- BS 4504 Flanges and boltings for pipes, valves and fittings
- BS 5146 Inspection and test of steel valves for the petroleum, petrochemical and allied industries.
- BS 5351 Steel ball valves for the petroleum, petrochemical and allied industries.
- BS 5750 Quality system.
- BS 6755 Testing of valves.

MSS-Manufacturers Standardization Society

- SP 6 Standard finishes for contact faces of pipe flanges and connecting-end flanges of valves and fittings.
- SP 25 Standard marking system for valves, fittings, flanges and unions.
- SP 45 Bypass and drain connection standard.

NACE-National Association of Corrosion Engineers

- MR 0175 Sulfide stress cracking resistant metallic materials for oil field equipment.

DBV THREEPIECE TRUNNION PARTS CONFIGURATION 2" FP-36"FP, CLASS 150,300,600,900,1500&2500

- End Connection
- RF
 - RTJ
 - WE
 - RFxWE
 - RTJxWE

- Weld End Wall Thickness
- XX ● See Weld Chart

- Body/Bolting Material NACE Conformance
- | | |
|---|--|
| NACE III.CI.III Bolting
● A105/B7
● SS/B7
● LF2/L7
● SS/L7
● LF2/L7
● A105/B7 | NACE II.CI.II Bolting
● A105/B7
● SS/B7M
● SS/L7M
● A105/B7M Cad
● LF2/L7
● SS/660SS |
|---|--|

- Trim
- 316SS
 - 410SS or CA-15M
 - CS w/3 mil ENP (Std. on 2" & larger)
 - LTCS (3mil ENP)

- Seat Insert/FS
- Teflon/FS
 - PEEK/FS

- Seal Material
- Viton
 - EPDM
 - HNBR

- Actuation
- Locking Handle upon request
 - Locking Gear Operator upon request
 - Bare Stem
 - For Actuator

BUTTWELD END PIPE SCHEDULE

Pipe Description	Nominal Pipe Size (in.) ● Schedule Code													
	2	3	4	6	8	10	12	14	16	18	20	22	24	
Outside Dia.(in.)	2.375	3.500	4.500	6.625	8.625	10.750	12.750	14.000	16.000	18.000	20.000	22.000	24.000	
(STD) Standard	-	-	.237	.280	.322	.365	.375	.375	.375	.375	.375	.375	.375	
Schedule 40	.154	.216	.237	.280	.322	.365	.406	.438	.500	.562	.593	-	.687	
XS	.218	.300	.337	.432	.500	.500	.500	.500	.500	-	-	0.500	-	
Schedule 80	.218	.300	.337	.432	.500	.593	.687	.750	.843	.937	1.031	1.125	1.218	
Schedule 160	.343	.438	.531	.718	.906	1.125	1.312	1.406	1.593	1.781	1.968	-	2.343	
XXS	.436	.600	.674	.864	.875	1.000	1.000	-	-	-	-	-	-	

● COMPONENT PARTS ● 2",3"& 4",CLASS 600,900 & 1500

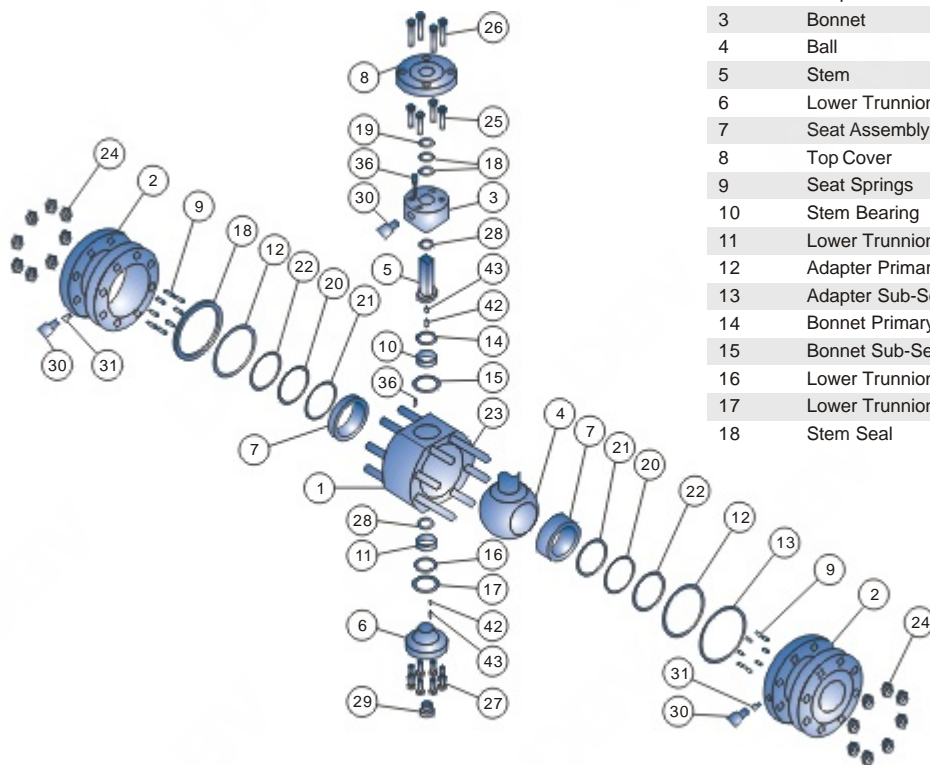

PARTS LIST

Part No	Description	Part No	Description
1	Body	19	Stem Sub-Seal
2	Adapter	20	Seat Seal
3	Bonnet	21	Seat Seal Backup
4	Ball	22	Seat Sub-Seal
5	Stem	23	Stud Body
6	Lower Trunnion	24	Nut Body
7	Seat Assembly	25	Cap Screw, Bonnet
8	Top Cover	26	Cap Screw, Top Cover
9	Seat Springs	27	Cap Screw, Lower Trunnion
10	Stem Bearing	28	Thrust Bearing
11	Lower Trunnion Bearing	29	Bleed/Drain Valve
12	Adapter Primary Seal	30	Injection Fitting
13	Adapter Sub-Seal	31	Ball Check
14	Bonnet Primary Seal	32	Drain Plug
15	Bonnet Sub-Seal	34	Key
16	Lower Trunnion Primary Seal	36	Alignment Pin, Bonnet
17	Lower Trunnion Sub-Seal	42	Antistatic Pin
18	Stem Seal	43	Antistatic Spring

● COMPONENT PARTS ● 6"-12",CLASS 600

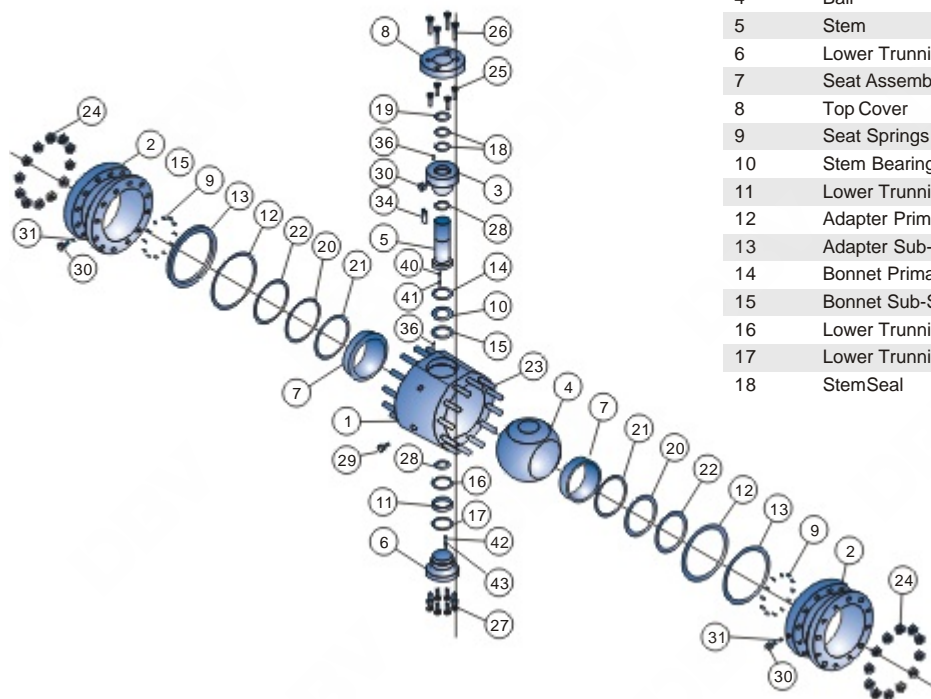

PARTS LIST

Part No	Description	Part No	Description
1	Body	19	Stem Sub-Seal
2	Adapter	20	Seat Seal
3	Bonnet	21	Seat Seal Backup
4	Ball	22	Seat Sub-Seal
5	Stem	23	Stud, Body
6	Lower Trunnion	24	Nut Body
7	Seat Assembly	25	Cap Screw, Bonnet
8	Top Cover	26	Cap Screw, TopCover
9	Seat Springs	27	Cap Screw, Lower Trunnion
10	Stem Bearing	28	Thrust Bearing
11	Lower Trunnion Bearing	29	Bleed/Drain Valve
12	Adapter Primary Seal	30	Injection Fitting
13	Adapter Sub-Seal	31	Ball Check
14	Bonnet Primary Seal	32	Drain Plug
15	Bonnet Sub-Seal	34	Key
16	Lower Trunnion Primary Seal	36	Alignment Pin, Bonnet
17	Lower Trunnion Sub-Seal	42	Antistatic Pin
18	Stem Seal	43	Antistatic Spring

- Component Parts ● 6"-12", Class 900 & 1500
- 14" & Larger, All Class

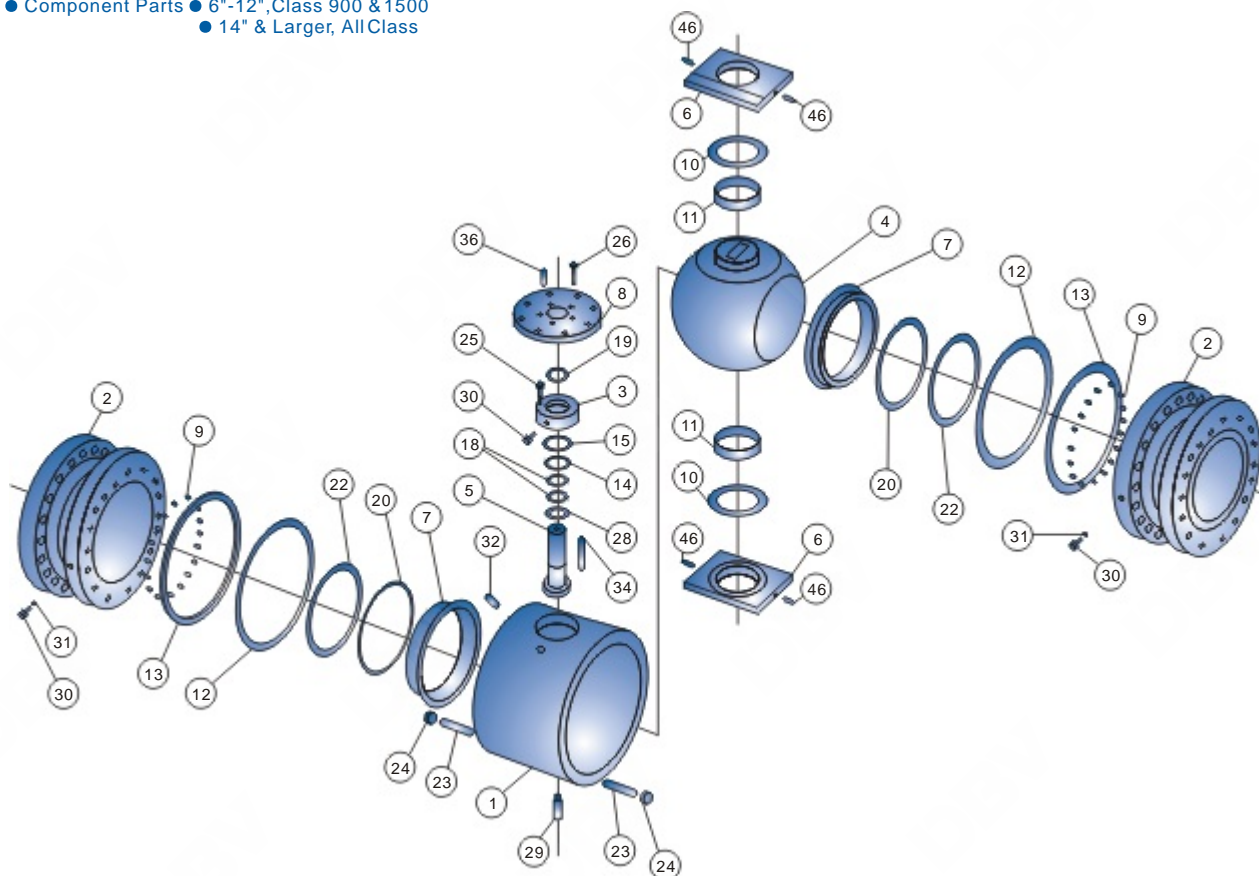

PARTS LIST

Part No	Description	Part No	Description
1	Body	18	Stem Seal
2	Adapter	19	Stem Sub-Seal
3	Bonnet	20	Seat Seal
4	Ball	21	Seat Seal Backup
5	Stem	22	Seat Sub-Seal
6	Trunnion Block	23	Stud, Body
7	Seat Assembly	24	Nut, Body
8	Top Cover	25	Cap Screw, Bonnet
9	Seat Springs	26	Cap Screw, Top Cover
10	Stem Bearing	28	Thrust Bearing
11	Lower Trunnion Bearing	29	Bleed/Drain Valve
12	Adapter Primary Seal	30	Injection Fitting
13	Adapter Sub-Seal	31	Ball Check
14	Bonnet Primary Seal	32	Drain Plug
15	Bonnet Sub-Seal	34	Key
16	Lower Trunnion Primary Seal	36	Alignment Pin, Bonnet
17	Lower Trunnion Sub-Seal	46	Trunnion Block Pin

THREE PIECE TRUNNION MOUNTED BALL VALVE

- Three Piece Body, FullPort or Reduced Bore
- Trunnion Mounted, Fire Safe, Blow-out Proof Stem
- Anti-static Device, Cavity Relieving Seats
- NACE MR-01-75, Optional Locking Device
- Designed to ASME B16.34, API 6D

Face to Face	API 6D
End Flange	ASME B16.5
Buttweld	ASME B16.25
Class	ASME CL150/300

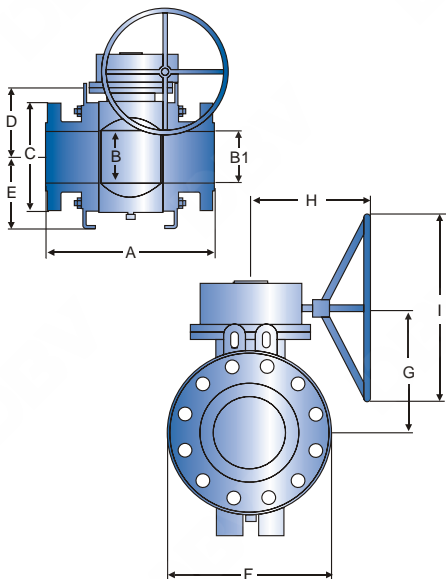

CLASS 150 DIMENSION

SIZE (in.)	A			B	B1	C	D	E	F	G	H	I	Unit: inch
	RF	RTJ	WE										
14	27.0	27.5	30.0	13.3	13.3	21.0	15.7	15.3	25.1	18.5	20.4	23.6	
16	30.0	30.5	33.0	15.3	15.3	23.5	16.7	17.7	28.0	19.4	18.7	27.6	
20x16	36.0	36.5	39.0	15.3	19.3	27.5	16.7	17.7	28.0	19.4	18.7	27.6	
18	34.0	34.5	36.0	17.2	17.2	25.0	19.1	19.5	31.9	22.3	22.6	27.6	
20	36.0	36.5	39.0	19.3	19.3	27.5	21.1	21.4	34.1	24.3	22.6	27.6	
24x20	42.0	42.5	45.0	19.3	23.3	32.0	21.1	21.4	34.1	24.3	22.6	27.6	
24	42.0	42.5	45.0	23.3	23.3	32.0	24.3	23.2	40.4	27.8	23.3	31.5	

CLASS 300 DIMENSION

SIZE (in.)	A			B	B1	C	D	E	F	G	H	I	Unit: inch
	RF	RTJ	WE										
14	30.0	30.6	30.0	13.3	13.3	23.0	15.7	15.3	18.5	25.1	20.4	23.6	
16	33.0	33.6	33.0	15.3	15.3	25.5	16.7	16.7	19.4	28.0	22.6	27.6	
20x16	39.0	39.8	39.0	15.3	19.3	30.5	16.7	16.7	19.4	28.0	22.6	27.6	
18	36.0	36.6	36.0	17.2	17.2	28.0	19.2	19.6	22.4	32.3	22.6	27.6	
20	39.0	39.8	39.0	19.3	19.3	30.5	21.2	21.6	24.7	34.4	23.3	31.5	
24x20	45.0	45.9	45.0	19.3	23.3	36.0	21.2	21.6	24.7	34.4	23.3	31.5	
24	45.0	45.9	45.0	23.3	23.3	36.0	24.6	23.4	29.3	40.9	27.3	35.4	

THREE PIECE TRUNNION MOUNTED BALL VALVE

- Three Piece Body, FullPort or Reduced Bore
- Trunnion Mounted, Fire Safe, Blow-out Proof Stem
- Anti-static Device, Cavity Relieving Seats
- NACE MR-01-75, Optional Locking Device
- Designed to ASME B16.34, API 6D

Face to Face	API 6D
End Flange	ASME B16.5
Buttweld	ASME B16.25
Class	ASME CL600

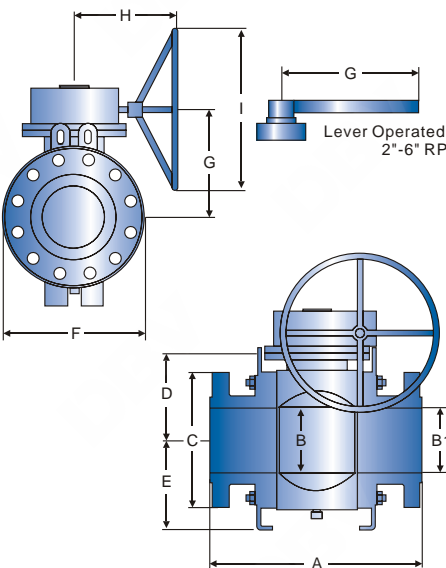

CLASS 600 DIMENSION

SIZE (in.)	A			B	B1	C	D	E	F	G	H	I	Unit: inch
	RF	RTJ	WE										
2	11.5	11.6	11.5	2.0	2.0	6.5	6.1	4.2	6.5	22.8	-	-	
3X2	14.0	14.1	14.0	2.0	3.0	8.3	6.1	4.2	6.5	22.8	-	-	
3	14.0	14.1	14.0	3.0	3.0	8.3	6.7	5.4	9.0	27.6	-	-	
4X3	17.0	17.1	17.0	3.0	4.0	10.7	6.7	5.4	9.0	27.6	-	-	
4	17.0	17.1	17.0	4.1	4.1	10.8	8.0	6.4	10.4	27.8	-	-	
6X4	22.0	22.1	22.0	4.1	6.0	14.0	8.0	6.4	10.4	27.8	-	-	
6	22.0	22.1	22.0	6.0	6.0	14.0	9.1	9.2	12.6	11.2	14.2	19.7	
8X6	26.0	26.1	26.0	6.0	8.0	16.5	9.1	9.2	12.6	11.2	14.2	19.7	
8	26.0	26.1	26.0	8.0	8.0	16.5	11.4	12.4	17.0	13.5	15.0	23.6	
10X8	31.0	31.1	31.0	8.0	10.0	20.0	11.4	12.4	17.0	13.5	15.0	23.6	
10	31.0	31.1	31.0	10.0	10.0	20.0	13.0	15.7	20.4	15.5	16.5	23.6	
12X10	33.0	33.1	33.0	10.0	12.0	22.0	13.0	15.7	20.4	15.5	16.5	23.6	
12	33.0	33.1	33.0	12.0	12.0	22.0	15.9	17.8	24.5	18.7	21.5	27.6	
14X12	35.0	35.1	35.0	12.0	13.3	23.7	15.9	17.8	24.5	18.7	21.5	27.6	
16X12	39.0	39.1	39.0	12.0	15.3	27.0	15.9	17.8	24.5	18.7	21.5	27.6	
14	35.0	35.1	35.0	13.3	13.3	23.7	15.7	15.3	25.1	18.9	23.1	31.5	
16	39.0	39.1	39.0	15.3	15.3	27.0	17.4	17.6	28.9	20.6	22.6	27.6	
20X16	47.0	47.2	47.0	15.3	19.3	32.1	17.4	17.6	28.9	20.6	22.6	27.6	
18	43.0	43.1	43.0	17.2	17.2	29.3	19.6	20.1	33.1	23.1	23.3	31.5	
20	47.0	47.2	47.0	19.3	19.3	32.0	22.2	21.3	36.2	27.0	27.3	35.4	
24X20	55.0	55.4	55.0	19.3	23.3	37.0	22.2	21.3	36.2	27.0	27.3	35.4	
24	55.0	55.4	55.0	23.3	23.3	37.0	24.6	23.5	41.1	30.8	37.4	27.6	

THREE PIECE TRUNNION MOUNTED BALL VALVE

- Three Piece Body, FullPort or Reduced Bore
- Trunnion Mounted, Fire Safe, Blow-out Proof Stem
- Anti-static Device, Cavity Relieving Seats
- NACE MR-01-75, Optional Locking Device
- Designed to ASME B16.34, API 6D

Face to Face	API 6D
End Flange	ASME B16.5
Buttweld	ASME B16.25
Class	ASME CL900/1500

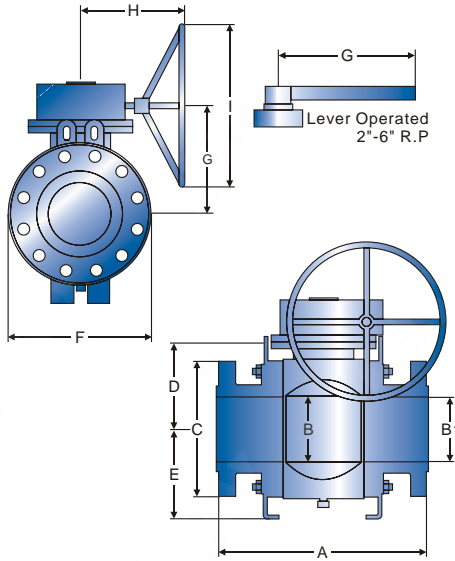

CLASS 900 DIMENSION

SIZE (in.)	A			B	B1	C	D	E	F	G	H	I
	RF	RTJ	WE									
2	14.5	14.6	14.5	2.0	2.0	8.5	5.8	4.6	7.3	22.8	-	-
3x2	15.0	15.1	15.0	2.0	3.0	9.5	5.8	4.6	7.3	22.8	-	-
3	15.0	15.1	15.0	3.0	3.0	9.5	7.0	5.7	9.3	27.6	-	-
4x3	18.0	18.1	18.0	3.0	4.0	11.5	7.0	5.7	9.3	27.6	-	-
4	18.0	18.1	18.0	4.1	4.1	11.5	8.5	6.9	11.3	33.7	-	-
6x4	24.0	24.1	24.0	4.1	6.0	15.0	8.5	6.9	11.3	33.7	-	-
6	24.0	24.1	24.0	6.0	6.0	15.0	10.0	10.0	14.2	12.1	14.8	23.6
8x6	29.0	29.1	29.0	6.0	8.0	18.5	10.0	10.0	14.2	12.1	14.8	23.6
8	29.0	29.1	29.0	8.0	8.0	18.5	11.7	12.6	17.3	14.2	21.5	27.6
10x8	33.0	33.1	33.0	8.0	10.0	21.5	11.7	12.6	17.3	14.2	21.5	27.6
10	33.0	33.1	33.0	10.0	10.0	21.5	13.5	16.0	20.9	16.2	20.4	23.6
12x10	38.0	38.1	38.0	10.0	12.0	24.0	13.5	16.0	20.9	16.2	20.4	23.6
12	38.0	38.1	38.0	12.0	12.0	24.0	16.4	18.2	25.4	19.6	23.1	31.5
14x12	40.5	40.9	40.5	12.0	12.8	25.3	16.4	18.2	25.4	19.6	23.1	31.5
16x12	44.5	44.9	44.5	12.0	14.8	27.8	16.4	18.2	25.4	19.6	23.1	31.5
14	40.5	40.9	40.5	12.8	12.8	25.3	15.6	16.5	24.8	18.7	23.1	31.5
16	44.5	44.9	44.5	14.8	14.8	27.8	18.3	19.4	29.3	21.8	23.3	31.5

CLASS 1500 DIMENSION

SIZE (in.)	A			B	B1	C	D	E	F	G	H	I
	RF	RTJ	WE									
2	14.3	14.6	14.5	2.0	2.0	8.5	6.8	5.3	8.4	22.0	-	-
3x2	18.3	18.6	18.5	2.0	3.0	10.5	6.8	5.3	8.4	22.0	-	-
3	18.3	18.6	18.5	3.0	3.0	10.5	8.6	7.1	11.8	27.6	-	-
4x3	21.2	21.6	21.5	3.0	4.1	12.2	8.6	7.1	11.8	27.6	-	-
4	21.2	21.6	21.5	4.1	4.1	12.2	9.2	7.8	13.0	39.4	-	-
6x4	27.4	28.0	27.8	4.1	5.7	15.5	9.2	7.8	13.0	39.4	-	-
6	27.4	28.0	27.8	5.7	5.7	15.5	11.3	11.2	16.5	13.9	20.4	23.6
8x6	32.8	33.1	32.8	5.7	7.6	19.0	11.3	11.2	16.5	13.9	20.4	23.6
8	32.8	33.1	32.8	7.6	7.6	19.0	13.7	14.5	21.2	16.4	22.6	27.6
10x8	39.0	39.4	39.0	7.6	9.5	23.0	13.7	14.5	21.2	16.4	22.6	27.6
10	39.0	39.4	39.0	9.5	9.5	23.0	15.6	17.9	24.8	18.8	23.1	31.5
12x10	44.5	45.1	44.5	9.5	11.4	26.5	15.6	17.9	24.8	18.8	23.1	31.5
12	44.5	45.1	44.5	11.4	11.4	26.5	19.1	20.9	30.7	22.3	23.1	31.5

DBV THREEPIECE TRUNNION BALL VALVE REF. WEIGHTS

Unit: lbs.

SIZE (in.)	PORT Class	ANSI	Valve Only	With Handle	With G.O.	SIZE (in.)	PORT Class	ANSI	Valve Only	With Handle	With G.O.	SIZE (in.)	PORT Class	ANSI	Valve Only	With Handle	With G.O.
2	FP	600	81	86	119	6	RP	600	368	377	413	14	FP	150	1781	-	1979
2	FP	900	114	118	168	6	FP	600	498	-	582	14	FP	300	2380	-	2578
2	FP	1500	169	173	223	6	RP	900	529	538	574	14	RP	600	2491	-	2779
2	FP	2500	Consult Factory			6	FP	900	762	-	854	14	FP	600	3020	-	3308
3	RP	600	96	101	134	6	RP	1500	816	-	897	14	FP	900	3339	-	3537
3	FP	600	160	168	214	6	FP	1500	1157	-	1272	16	RP	150	1610	-	1808
3	RP	900	147	152	201	6	RP/FP	2500	Consult Factory			16	FP	150	2799	-	2997
3	FP	900	216	223	270	8	RP	600	604	-	688	16	RP	300	2332	-	2530
3	RP	1500	210	214	264	8	FP	600	992	-	1082	16	FP	300	2870	-	3064
3	FP	1500	386	390	431	8	RP	900	912	-	1004	16	RP	600	3042	-	3330
3	RP/FP	2500	Consult Factory			8	FP	900	1344	-	1456	16	FP	600	3791	-	4084
4	RP	600	216	223	270	8	RP	1500	1356	-	1471	16	RP	900	3947	-	4145
4	FP	600	286	295	331	8	FP	1500	2149	-	2345	16	FP	900	4596	-	5072
4	RP	900	288	296	342	8	RP/FP	2500	Consult Factory			16	FP	1500	9393	-	10,235
4	FP	900	385	395	430	10	RP	600	1256	-	1346	24	FP	150	7680	-	8156
4	RP	1500	485	494	530	10	FP	600	1653	-	1768	24	RP	300	6063	-	6352
4	FP	1500	617	-	698	10	RP	900	1499	-	1611	24	FP	300	7960	-	8802
4	RP/FP	2500	Consult Factory			10	FP	900	2010	-	2208	24	RP	600	7475	-	8317
Note: Consult factory for sizes not shown.						10	RP	1500	2628	-	2824	24	FP	600	12,125	-	12,995
						10	FP	1500	3440	-	3740	24	RP	900	12,303	-	13,145
						10	RP/FP	2500	Consult Factory			24	FP	900	15,500	-	16,370
						12	RP	600	1834	-	1949						
						12	FP	600	2535	-	2823						
						12	RP	900	2226	-	2424						
						12	FP	900	2865	-	3164						
						12	RP	1500	4156	-	4456						
						12	FP	1500	4012	-	4312						
						12	RP/FP	2500	Consult Factory								

Note: All weights listed are estimated, Consult factory for sizes not shown.

THREE PIECE TRUNNION BALL VALVE TOPWORKS (IN.) & STEM TORQUE DATA (IN.-LBS.)

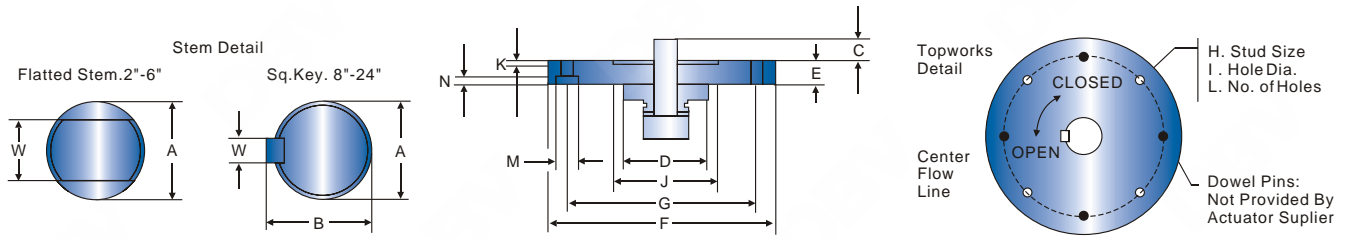

SIZE (in.)	ANSI Class	A	B	C	D	E	F	G	H Stud Sz. UNC	I Hole Dia.	J	K	L No.Of Holes	M C.Line Bore	N Bore Depth	W	Max Stem Sheer Torq. ft.-lbs.	Break Torq. in.-lbs.	Torq.Express.(1) For P<=2160 PSI in.-lbs.(2)(3)	
2	600	0.871	-	1.319	3.760	0.709	5.906	4.921	1/2-13	0.531	-	-	4	0.787	0.512	*0.558	134	1314	0.409*P+	
2	900	0.871	-	1.345	3.858	0.709	5.906	4.921	1/2-13	0.531	-	-	4	0.787	0.512	*0.558	135	1616	708.20	
2	1500	1.103	-	1.988	4.094	1.063	5.906	4.921	1/2-13	0.531	-	-	4	0.787	0.551	*0.746	306	2224		
3	600	1.378	-	2.010	4.429	0.787	6.240	5.433	1/2-13	0.531	-	-	4	-	-	*0.994	405	4151	1.758*P+	
3	900	1.378	-	2.000	4.941	0.945	6.713	5.433	1/2-13	0.531	-	-	4	0.807	0.500	*0.994	630	5452	1548.75	
3	1500	1.493	-	1.973	4.921	1.181	6.693	5.512	5/8-11	0.657	-	-	4	1.024	0.650	*0.993	726	8062		
4	600	1.497	-	1.687	5.020	1.220	6.890	5.512	5/8-11	0.657	3.939	0.118	4	0.984	0.630	*0.996	725	6043	2.319*P+	
4	900	1.497	-	1.687	5.020	1.220	6.890	5.512	5/8-11	0.657	3.939	0.118	4	0.984	0.630	*0.996	728	7759	2610.75	
4	1500	1.774	-	2.402	5.925	1.220	8.268	6.496	3/4-10	0.787	5.120	0.118	4	1.181	0.787	*1.247	1337	11.203		
6	600	1.931	-	2.179	4.921	1.299	6.909	5.512	5/8-11	0.657	3.939	0.118	4	1.000	0.669	*1.247	1624	14.580	7.446*P+	
6	900	1.992	-	1.991	4.921	1.378	8.287	6.496	3/4-10	0.787	5.120	0.118	4	1.181	0.787	*1.247	1695	20.090	3559.47	
6	1500	2.493	-	2.795	6.299	1.181	11.811	10.000	5/8-11	0.669	7.880	0.118	8	-	-	*1.747	3722	31.147		
8	600	2.870	3.191	3.588	6.297	1.732	8.287	6.496	3/4-10	0.787	5.120	0.157	4	1.165	0.787	0.750	7460	22.628	11.535*P+	
8	900	2.870	3.191	3.780	6.496	1.575	11.811	10.000	5/8-11	0.669	7.877	0.157	8	-	-	0.750	7460	31.164	5556.03	
8	1500	2.870	3.191	3.299	6.496	1.575	11.811	10.000	5/8-11	0.669	7.877	0.118	8	-	-	0.750	7460	48.293		
10	600	3.240	3.613	3.581	6.900	0.986	11.319	10.000	5/8-11	0.657	7.877	0.118	8	-	-	0.875	10.631	29.042	14.402*P+	
10	900	3.240	3.617	3.972	7.096	1.260	11.811	10.000	5/8-11	0.657	7.877	0.118	8	-	-	0.875	10.631	39.699	7726.94	
10	1500	3.240	3.617	3.775	7.490	1.457	11.811	10.000	5/8-11	0.669	7.877	0.118	8	-	-	0.875	10.631	61.086		
12	600	3.994	4.426	4.244	8.500	1.319	12.000	10.000	5/8-11	0.657	7.877	0.118	8	-	-	1.000	20.315	34.639	16.6*P+	
12	900	3.994	4.426	4.210	9.051	1.813	13.780	11.732	3/4-10	0.787	9.057	0.199	8	-	-	1.000	20.315	46.923	10071.30	
12	1500	3.990	4.426	4.210	9.445	1.813	13.780	11.732	3/4-10	0.787	9.057	0.199	8	-	-	1.000	20.315	71.574		
14	150	3.240	3.613	3.603	8.071	1.299	11.811	10.000	5/8-11	0.657	7.875	0.118	8	-	-	0.875	7444	25.000	28.32*P+	
14	300	3.240	3.613	3.603	8.071	1.299	11.811	10.000	5/8-11	0.657	7.875	0.118	8	-	-	0.875	7444	37.886	16929.17	
14	600	3.240	3.613	3.603	8.071	1.299	13.780	11.732	3/4-10	0.787	9.057	0.118	8	-	-	0.875	10.631	58.843		
14	900	3.240	3.613	3.287	7.874	1.457	13.780	11.732	3/4-10	0.827	9.057	0.118	8	-	-	0.875	10.631	79.000		
16	150	3.240	3.613	3.838	8.228	1.299	11.811	10.000	5/8-11	0.657	7.875	0.118	8	-	-	0.875	10.631	33.602	37.48*P+	
16	300	3.240	3.613	3.838	8.228	1.299	11.811	10.000	5/8-11	0.657	7.875	0.118	8	-	-	0.875	10.631	50.655	22919.73	
16	600	4.333	4.749	4.114	8.898	1.299	13.228	11.732	3/4-10	0.787	9.057	0.118	8	-	-	1.000	26.103	78.390		
16	900	4.333	4.749	4.568	8.543	1.000	13.780	11.732	3/4-10	0.787	9.057	0.118	8	-	-	1.000	26.103	106.125		
16	1500	Consult Factory																		
18	150	4.333	4.749	3.996	9.055	1.299	13.228	11.732	3/4-10	0.787	9.057	0.118	8	-	-	1.000	26.103	45.663	62.74*P+	
18	300	4.333	4.749	3.996	9.055	1.299	13.228	11.732	3/4-10	0.787	9.057	0.118	8	-	-	1.000	26.103	74.210	27781.92	
18	600	4.333	4.749	3.996	9.055	1.299	13.780	11.732	3/4-10	0.787	9.057	0.118	8	-	-	1.000	26.103	120.637		
18	900	4.742	5.284	3.267	11.807	1.000	18.701	15.984	1-1/2-8	1.575	11.819	0.315	8	-	-	1.250	60.984	167.065	91.86*P+	
20	150	4.333	4.749	4.528	9.248	1.000	13.386	11.732	3/4-10	0.787	9.057	0.118	8	-	-	1.000	26.103	57.608	31428.12	
20	300	4.323	4.749	4.449	9.248	1.417	13.780	11.732	3/4-10	0.787	9.057	0.118	8	-	-	1.000	26.103	99.405		
20	600	4.333	4.749	4.382	9.839	1.000	13.780	11.732	3/4-10	0.787	9.057	0.118	8	-	-	1.000	26.103	167.381		
20	900	4.742	5.284	5.118	11.807	1.000	18.701	15.984	1-1/2-8	1.575	11.819	0.315	8	-	-	1.250	60.984	235.357	141.23*P+	
24	150	4.333	4.749	4.429	9.248	1.417	13.780	11.732	3/4-10	0.787	9.057	0.118	8	-	-	1.000	26.103	110.228	69976.95	
24	300	4.333	4.749	4.429	9.248	1.417	13.780	11.732	3/4-10	0.787	9.057	0.118	8	-	-	1.000	26.103	174.487		
24	600	4.725	5.257	4.331	11.020	2.362	18.701	15.984	1-1/2-8	1.575	11.819	0.394	8	-	-	1.250	33.100	278.997		
24	900	5.741	6.391	6.259	12.386	1.181	18.701	15.984	1-1/2-8	1.575	11.817	0.118	8	-	-	1.500	108.306	383.508		
30	600	Consult Factory																		
36	600	Consult Factory																		

* Stem with Double 'D' Flat Style

Note: (1) Torque at maximum differential pressure are tabulated
 (2) Torques expressions are suggested for other differential pressure
 (3) Differential pressure "P" in torque expressions in PSI

Pressure ratings are according to API 6D/ASME 16.34
 Class 150 P= 285 Class 900 P=2220
 Class 300 P= 740 Class 1500 P=3705
 Class 600 P= 1480

THREE PIECE TRUNNIONBALL VALVE ENGINEERING DATA

Flow Coefficient (Cv)

SIZE (in.)	285 psi	740 psi	1480 psi	2220 psi	3705 psi
2	-	-	350	320	330
3x2	-	-	190	185	187
3	-	-	1000	910	830
4x3	-	-	560	505	510
4	-	-	1850	1760	1660
6x4	-	-	800	730	742
6	-	-	4400	4300	4167
8x6	-	-	2150	2010	2033
8	-	-	8450	8400	8013
10x8	-	-	4500	4160	4051
10	-	-	14.25	14.160	13.909
12x10	-	-	8000	7300	7117
12	-	-	22.790	21.230	17.073
14x12	-	-	13.990	-	-
16x12	-	-	-	-	-
14	32,600	30,990	28,600	26,000	24,276
16x14	14,780	14,750	14,720	14,690	14,247
16	44,700	42,600	39,250	36,600	33,215
20x16	14,870	14,860	14,850	14,830	14,795
18	87,825	56,225	57,410	48,665	43,402
20	74,775	71,800	65,463	62,239	55,931
24x20	26,768	26,755	25,698	26,659	-
22	91,789	88,537	81,305	-	-
24	113,284	109,414	98,963	93,993	83,926

Note: Consult factory for sized not shown.

METHOD OF CALCULATING FLOW

The Flow Coefficient "Cv" of a valve is the flow rate of water (gallons/minute) through a fully opened valve, with a pressure drop of 1 psi across the valve. To find the flow of liquid through valve from the Cv, use the following formulas:

LIQUID FLOW

QL = flow rate of liquid (gal./min.)
 ΔP = differential pressure across the valve (psi)
 G = specific gravity of liquid (for water, G=1)

$$Q_L = C_v \sqrt{\frac{\Delta P}{G}}$$

GAS FLOW

Qg = flow rate of gas (CFH at STP)
 P_2 = outlet pressure (psia)
 g = Specific gravity of gas (for air, g = 1.000)

$$Q_g = 61 C_v \sqrt{\frac{P_2 \Delta P}{g}}$$

For non-critical flow $\left\{ \frac{\Delta P}{P_2} < 1.0 \right\}$

BODY & TRIM MATERIALS

Part	Material
Body/Adapter	A105, LF2, F316SS
Ball/Stem	F316SS or CS+5 mil ENP
Seat	Teflon, PEEK

PRESSURE RATING (PSIG)

Material	ANSI Cl. 150	ANSI Cl. 300	ANSI Cl. 600	ANSI Cl. 900	ANSI Cl. 1500
A105, LF2	285	740	1480	2220	3705
F316	275	720	1440	2160	3600

LOW TEMPERATURE LIMITS

Body Material	° F	° C	Seat Material	° F	° C
A105	-20	-29	PEEK	-50	-46
LF2	-50	-46	Teflon	-50	-46
F316	-50	-46			

Seat Material ° F ° C

Viton	-20	-29
NBR	-40	-40

PRESSURE TEMPERATURE CHART (CARBON STEEL)

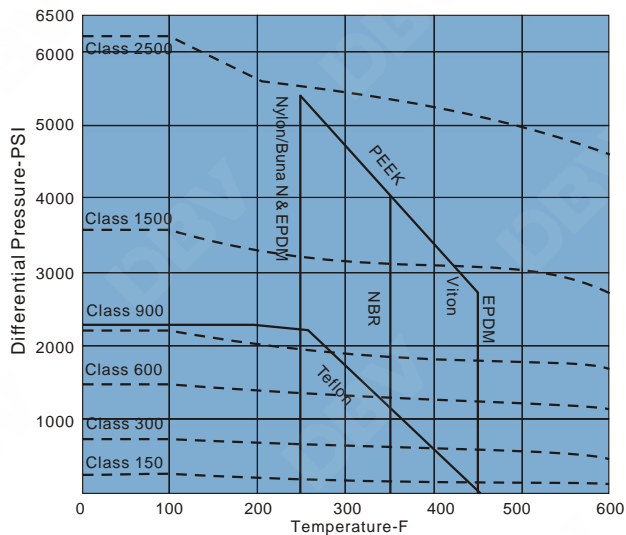

TOP ENTRY BALL VALVES

This top entry valve with one-piece trunnion supported ball conforms to API specifications 6A, 6D and ANSI B16.34. All seats are retained in metal holders which are spring-loaded against the ball for low pressure, fire safe sealing.

GENERAL DESIGN FEATURES

- One-piece flange top-entry trunnion design
- Double block and bleed
- One-piece ball and stem assures precise positioning
- Anti blowout one-piece ball/stem design
- O-rings plus fire safe packing prevents leakage
- Corrosion resistant low friction bearings
- Inconel wave springs provide upstream and downstream sealing
- Stainless Steel Sealant injection fittings for emergency stem of seat sealing
- Inline repairable due to reasonable seat retainer design
- Minimized torque required to open and close valve
- Anti-static grounding between ball, stem and body
- Integral top works direct mounting pad
- ANSI B16.34
- API 6D, API 6A, 607 and 6FA
- NACE MR 0175
- CE Marked (P.E.D.97/13/EC, Cat.3)

2" thru 16" class 150, 300 and 600,
2" thru 12" class 900, 1500 and 2500.

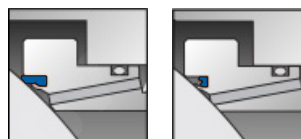
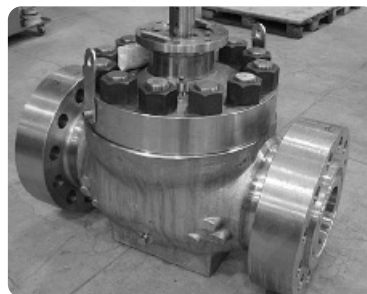

Before

After

FIRE SAFE FUNCTION

In case of fire and seat construction damage, fire safe requirements are accomplished with automatic metal-to-metal positive sealing

TECHNICAL SEATING FEATURES

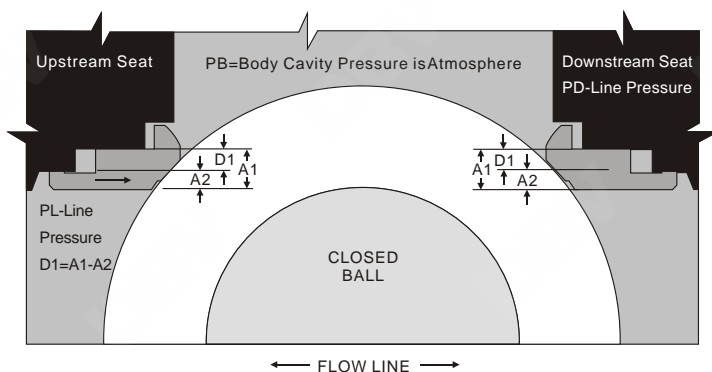

SELF RELIEVING SEAT DESIGN

Upstream Seat: The difference in the area (D1) times the line pressure creates a "piston effect" which forces the seat against the ball surface. Also the springs behind the seat adds the force to the seat which keeps the seat in contact with the ball surface by providing the tight seal.

Downstream Seat: When the body cavity pressure exceeds the spring pressure, automatic pressure relief will occur by relieving the body cavity pressure past the downstream seat. This eliminated the need for the body relief valve.

DOUBLE BLOCK AND BLEED

The double block and bleed condition is available in all seat design configurations. When the ball is in the closed position the body cavity pressure may be drained down to 'zero' by opening the bleed valve and draining the fluid by removing the drain plug. Each seat works independently assuring tight shut off seal against ball on the upstream and downstream side.

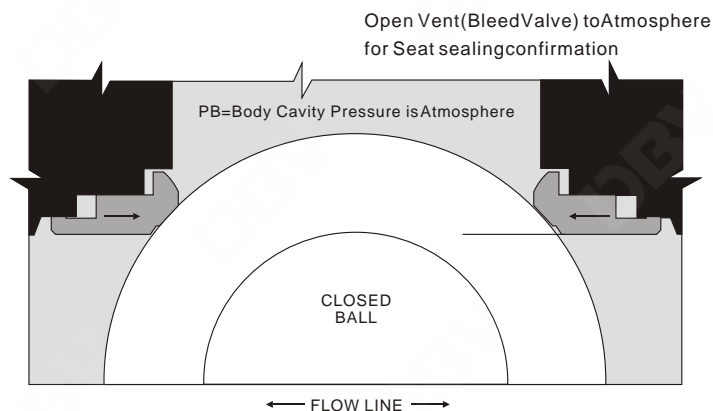

DESIGN FEATURES

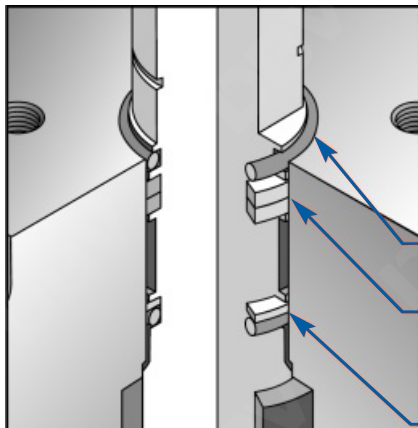

FIRESAFE STANDARD SEAL

2"-6" Class 600-1500
14"-16" Class 600
All Sizes Class 2500

Weather Seal
Stem Packing
Braided Carbon Rope
Primary Stem Seal

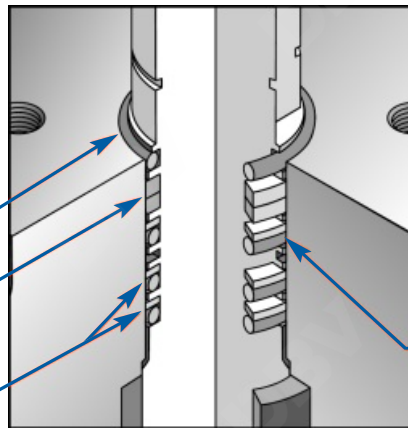

FIRESAFE STANDARD SEAL

8"-12" Class 600-1500

Secondary Stem Seal

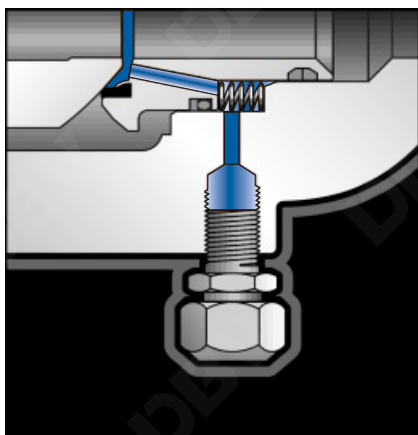

EMERGENCY SEAT SEAL

Special sealants may be injected into fittings that are located on the adapter flanges to restore sealing integrity if seat sealing surface is damaged. A second internal check valve provides backup to the fitting.

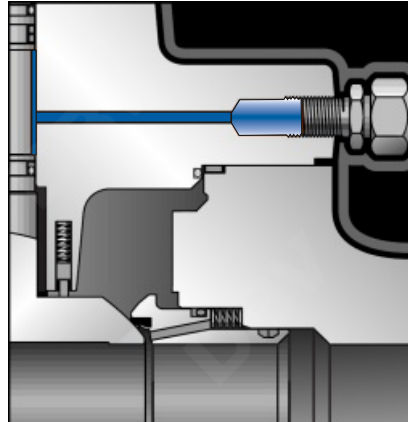

EMERGENCY SEALANT INJECTION SYSTEM

The Sealant Injection System located on the bonnet can be utilized in case of emergencies, o-ring damage, or if stem leakage occurs.

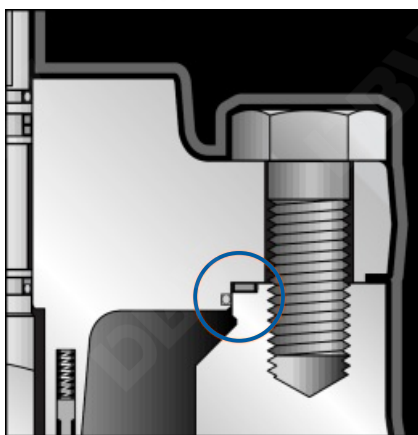

DOUBLE SEALED ENVELOPE CONNECTIONS

Double o-rings or a combination of an o-ring and Fire-Safe gasket on body/bonnet connections to ensure positive sealing. This makes these valves suitable for above or below ground service.

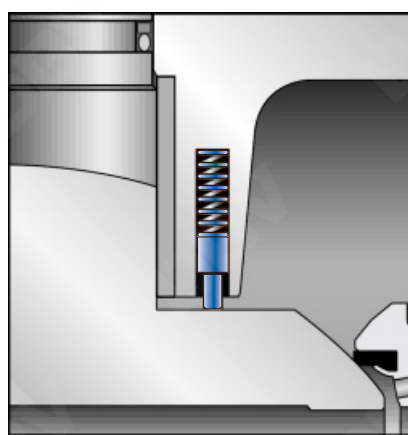

ANTISTATIC DEVICE

A spring between the bonnet and the ball permits electrical continuity

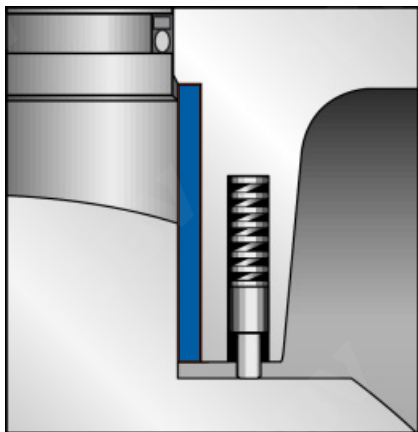

HEAVY DUTY BEARINGS

Heavy-duty PTFE lined bearing eliminates the need of lubricating stem and trunnion journals, resulting in smooth and easy operation of valve. Upper stem and lower trunnion bearings balance the pressure load on the ball by reducing friction between ball and seat.

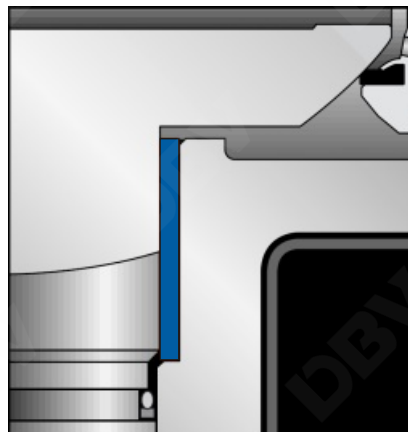

HEAVY DUTY BEARINGS

Heavy duty bearing supported in all valve classes

APPLICABLE STANDARDS

The following list contains the most important applicable standards for ball valves DBV valves may be designed,

API-American Petroleum Institute

- Spec.6A Specification for wellhead and Christmas tree equipment.
- Spec.6D Specification for pipeline valves,
- Spec.RP6F Recommended practice for fire testing of valves,
- Spec.6FA Specification for fire testing of valves,
- Std.598 Valve inspection and test.
- Std.605 Large diameter carbon steel flanges,
- Std.607 Fire test for soft seated quarter-turn valves.

ASME/ANSI-American National Standard

- B 16.5 Steel pipe flanges and flanged fittings.
- B 16.10 Face-to-face and end-to-end dimensions of ferrous valves.
- B 16.25 Butt welding ends.
- B 16.34 Steel valves-Flanged and butt welding ends.
- B 31.3 Chemical plant and petroleum refinery piping
- B 31.4 Liquid petroleum transportation piping systems.
- B 31.8 Gas transmission and distribution piping systems.

ASTM-American Society For Testing Materials

British Standard

- BS 1503 Specification for steel forgings for pressure purposes.
- BS 1504 Specification for steel castings for pressure purposes.
- BS 1560 Steel pipe flanges and flanged fittings.
- BS 2080 Face-to-face, center-to-face, end-to-end, and center-to-end dimensions of flanged and butt-welding end steel valves for the petroleum, petrochemical and allied industries.

Manufactured and tested in accordance with Other international standards on request.

British Standard-cont

- BS 4504 Flanges and boltings for pipes, valves and fittings.
- BS 5146 Inspection and test of steel valves for the petroleum, petrochemical and allied industries.
- BS 5351 Steel ball valves for the petroleum, petrochemical and allied industries.
- BS 5750 Quality system.
- BS 6755 Testing of valves.

EC-EUROPEAN COMMUNITY

CE marked (p.e.d.97/23/ec.cat.3)

ISO-International Organization for Standardization
ISO 9001:2000 Quality systems-Model for quality assurance in design/development, production, installation and servicing.

MSS-Manufacturers Standardization Society

- SP 6 Standard finishes for contact faces of pipe flanges and connecting-end flanges of valves and fittings.
- SP 25 Standard marking system for valves, fittings, flanges and unions.
- SP 44 Steel pipeline flanges.
- SP 45 By-pass and drain connection standard.
- SP 55 Quality standard for steel castings-visual method.
- SP 61 Hydrostatic testing of steel valves.
- SP 72 Ball valves with flanged or butt-welding ends for general service.

NACE-National Association of Corrosion Engineers

- Me0175 Sulfide stress cracking resistant metallic materials for oil field equipment.

TOP ENTRY BALL VALVE PARTS CONFIGURATION

<p>End Connection —</p> <ul style="list-style-type: none"> • WE x WE • RF x WE • RT J x WE <p>NACE Conformance —</p> <ul style="list-style-type: none"> • NACE II • CI.II Boting <p>Body/Bolting Material —</p> <ul style="list-style-type: none"> • A216 WCB (CS)B7M • SS/B7M • A352 LCC/L7M • SS/660SS 	<p>Trim —</p> <ul style="list-style-type: none"> • 316SS • CS (3 mil ENP) • LCC (3 mil ENP) • 316SS w/Drain • CS (3 mil ENP) w/Drain <p>Seat Insert/FS —</p> <ul style="list-style-type: none"> • PEEK/FS 	<p>Seal Material —</p> <ul style="list-style-type: none"> • Viton • EPDM • Low Temp BunaN • Handle • Gear Operator <p>Actuation —</p> <ul style="list-style-type: none"> • Handle w/Locking Device • Gear Operator w/Locking Device • Bare Stem • For Actuation
---	---	--

BUTT WELD END SCHEDULE

Pipe Description	Nominal Pipe Size (in.) • Schedule Code								
	2	3	4	6	8	10	12	14	16
Outside Dia.(in.)	2.375	3.500	4.500	6.625	8.625	10.750	12.750	14.000	16.000
(STD) Standard	-	-	.237	.280	.322	.365	.375	.375	.375
Schedule 40	.154	.216	.237	.280	.322	.365	.406	.438	.500
Schedule 60	-	-	-	-	.406	.500	.562	.593	.656
XS	.218	.300	.337	.432	.500	.500	.500	.500	.500
Schedule 80	.218	.300	.337	.432	.500	.593	.687	.750	.843
Schedule 120	-	-	.438	.562	.718	.843	1.000	1.093	1.218
Schedule 160	.343	.438	.531	.718	.906	1.125	1.312	1.406	1.593
XXS	.436	.600	.674	.864	.875	1.000	1.000	-	-

Consult factory for other wall thicknesses.

● Component Parts

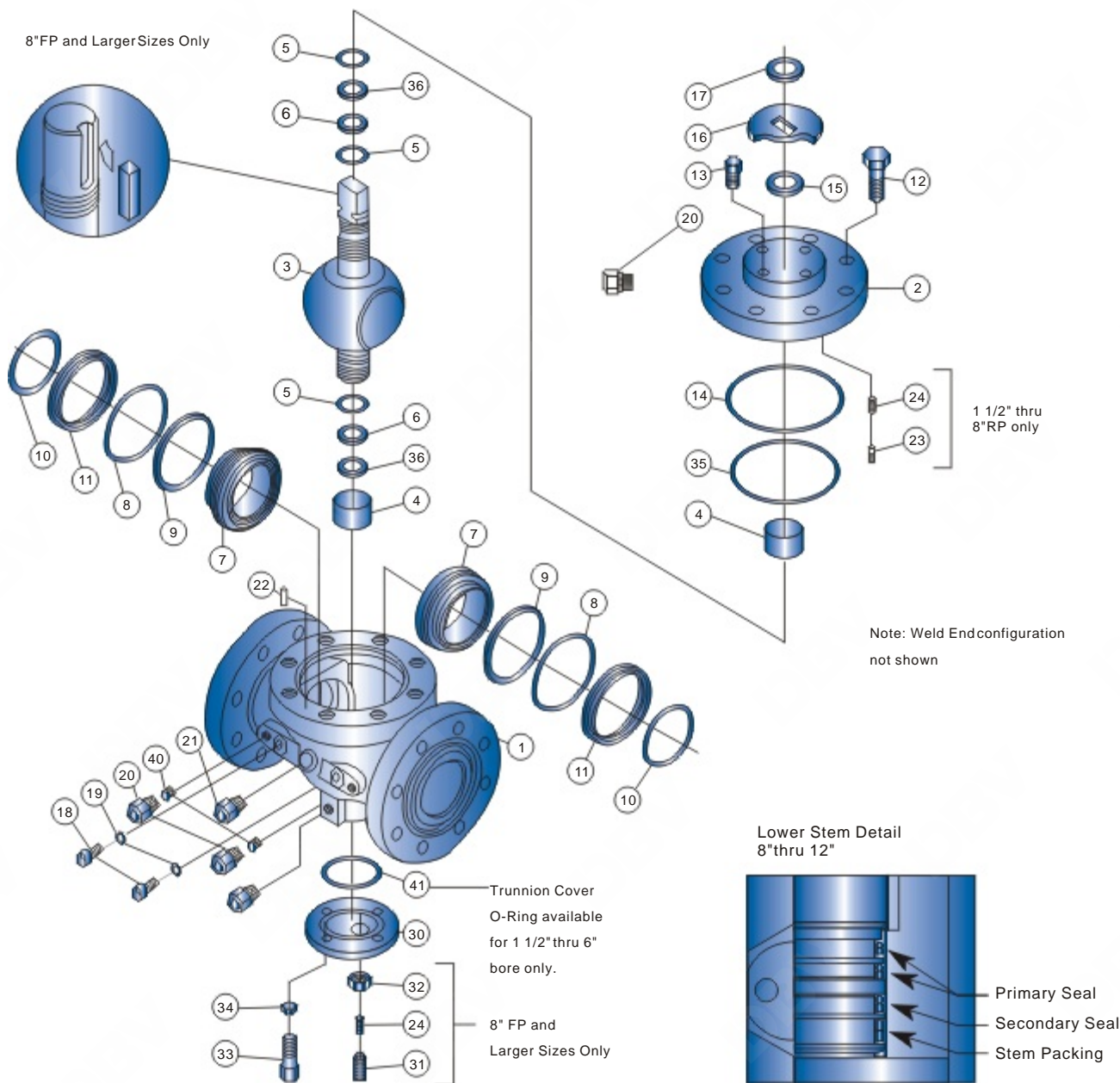

PARTS LIST

S.N	Description	S.N	Description	S.N	Description	S.N	Description
1	Body	10	Seat Sub Seal/ Braided Carbon Rope	18	Retract. Port Screw	31	Thrust Adjust Screw
2	Bonnet	11	Wave Spring	19	Retract. Port Seal	32	Jam Nut
3	Ball/Stem	12	Bonnet Cap Screw	20	Injection Fitting	33	Thrust Plate Bolt
4	Trunnion Bearing	13	Stop Screw	21	Bleed Valve	34	Lock washer
5	Stem Seal	14	Bonnet Gasket/Seal	22	Bonnet Align.Pin	35	Bonnet Primary Seal
6	Stem Back-up Ring	15	Stem Bearing	23	Grounding Plunger	36	Stem Packing/ Braided Carbon Rope
7	Seat	16	Stop Plate	24	Grounding Spring	40	Internal Ball Check
8	Seat O-Ring	17	Retainer	29	Key	41	Trunnion Cover O-Ring
9	Seat Back-up Ring			30	Thrust Plate		

TOP ENTRY BALL VALVE

- One Piece Uni-body Top Entry, Double Block and Bleed
- Full Port, Fire Safe, Blow-out Proof Stem
- Anti-static Device, Cavity Relieving Seats
- NACE MR-01-75, Optional Locking Device
- Designed to ASME B16.34, API 6D

Face to Face	API 6D
End Flange	ASME B16.5
Buttweld	ASME B16.25
Class	ASME CL600

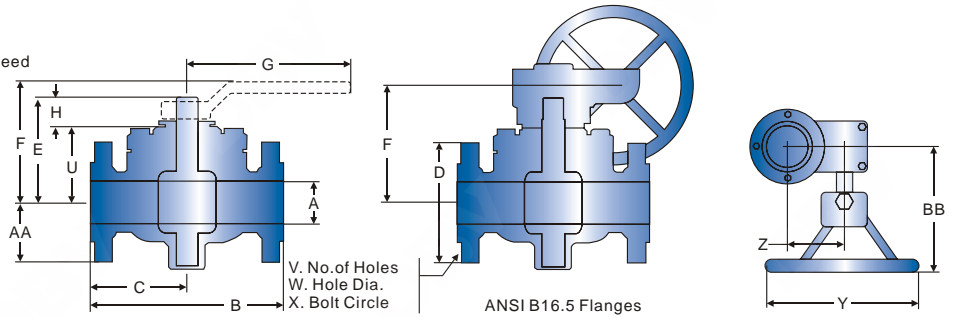

CLASS 600 DIMENSION

SIZE (in.)	W.T.(lbs.)			A	B		C		D	E	F	G	H	U	V	W	X	Y	Z	AA	BB	Ring Groove RTJ	Unit: inch
	Valve Only	W/ H.O	W/ G.O		RF	RTJ	RF	RTJ															
2X2	71	75	79	2-1/16	11-1/2	11-5/8	5-3/4	5-13/16	6-1/2	6-1/2	7-9/32	6	22	1-3/16	4-7/8	8	3/4	5	8	1-3/4	4-7/8	7-3/16	R-23
3X2	93	97	101	2-1/16	14	14-1/8	7	7-1/16	8-1/4	6-1/2	7-19/32	6	22	1-3/16	4-7/8	8	7/8	6-5/8	8	1-3/4	4-7/8	7-3/16	R-31
3X3	128	136	139	3-1/8	14	14-1/8	7	7-1/16	8-1/4	7-5/8	8-19/32	6-7/8	30	1-11/16	5-1/2	8	7/8	6-5/8	10	2-1/2	5-3/4	7-1/2	R-31
4X3	169	177	180	3-1/8	17	17-1/8	8-1/2	8-9/16	10-3/4	7-5/8	8-19/32	6-7/8	30	1-11/16	5-1/2	8	1	8-1/2	10	2-1/2	5-3/4	7-1/2	R-37
4X4	229	241	250	4-1/16	17	17-1/8	8-1/2	8-9/16	10-3/4	9-1/2	10-19/32	8-15/32	48	1-31/32	7-3/32	8	1	8-1/2	12	2-1/2	6-1/2	9-1/4	R-37
6X4	324	336	345	4-1/16	22	22-1/8	11	11-1/16	14	9-1/2	10-19/32	8-15/32	48	1-31/32	7-3/32	12	1-1/8	11-1/2	12	2-1/2	6-1/2	9-1/4	R-45
6X6	456	470	487	6	22	22-1/8	11	11-1/16	14	11-7/16	12-7/16	10-7/16	48	2-13/32	8-9/16	12	1-1/8	11-1/2	24	3-1/2	8-5/16	11-15/16	R-45
8X6	605	619	636	6	26	26-1/8	13	13-1/16	16-1/2	11-7/16	12-7/16	10-7/16	48	2-13/32	8-9/16	12	1-1/4	13-3/4	24	3-1/2	8-5/16	11-15/16	R-49
8X8	852	-	939	8	26	26-1/8	13	13-1/16	16-1/2	14-3/8	-	13-3/8	-	3-1/8	11-1/4	12	1-1/4	13-3/4	24	4-5/8	10-1/8	14-5/8	R-49
10X8	1024	-	1111	8	31	31-1/8	15-1/2	15-9/16	20	14-3/8	-	13-3/8	-	3-1/8	11-1/4	16	1-3/8	17	24	4-5/8	10-1/8	14-5/8	R-53
10X10	1433	-	1528	10	31	31-1/8	15-1/2	15-9/16	20	16-5/8	-	16-1/16	-	3-11/16	12-15/16	16	1-3/8	17	30	4-5/8	11-7/8	17-3/16	R-53
12X10	1546	-	1636	10	33	33-1/8	16-1/2	16-9/16	22	16-5/8	-	16-1/16	-	3-11/16	12-15/16	20	1-3/8	19-1/4	30	4-5/8	11-7/8	17-3/16	R-57
12X12	1963	-	2123	12	33	33-1/8	16-1/2	16-9/16	22	19-3/8	-	21-1/2	-	4-1/4	15-1/8	20	1-3/8	19-1/4	20	6-1/4	14-1/2	18-3/8	R-57
14X13/4	2610	-	2770	13-1/4	35	35-1/8	17-1/2	17-9/16	23-3/4	19-5/8	-	21-3/4	-	4-1/4	15-3/8	20	1-1/2	20-3/4	36	6-1/4	14	20-5/8	R-61
16X13-1/4	2792	-	2952	13-1/4	39	39-1/8	19-1/2	19-9/16	27	19-5/8	-	21-3/4	-	4-1/4	15-3/8	20	1-5/8	23-3/4	36	6-1/4	14	20-5/8	R-65
16X15-1/4	3130	-	3269	15-1/4	39	39-1/8	19-1/2	19-9/16	27	20-3/4	-	22-7/8	-	4-1/4	16-1/2	20	1-5/8	23-3/4	36	6-1/4	15-1/4	20-5/8	R-65

TOP ENTRY BALL VALVE

- One Piece Uni-body Top Entry, Double Block and Bleed
- Full Port, Fire Safe, Blow-out Proof Stem
- Anti-static Device, Cavity Relieving Seats
- NACE MR-01-75, Optional Locking Device
- Designed to ASME B16.34, API 6D

Face to Face	API 6D
End Flange	ASME B16.5
Buttweld	ASME B16.25
Class	ASME CL900

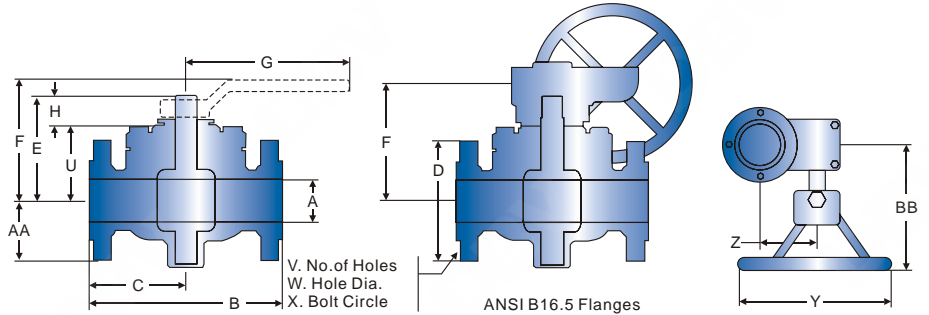

CLASS 900 DIMENSION

SIZE (in.)	W.T.(lbs.)			A	B		C		D	E	F	G	H	U	V	W	X	Y	Z	AA	BB	Ring Groove RTJ	Unit: inch
	Valve Only	W/ H.O	W/ G.O		RF	RTJ	RF	RTJ															
2X2	116	120	124	2-1/16	14-1/2	14-5/8	7-1/4	7-5/16	8-1/2	6-1/2	7-19/32	6	22	1-3/16	4-7/8	8	1	6-1/2	8	1-3/4	5	7-3/16	R-24
3X2	129	133	137	2-1/16	15	15-1/8	7-1/2	7-9/16	9-1/2	6-1/2	7-19/32	6	22	1-3/16	4-7/8	8	1	7-1/2	8	1-3/4	5	7-3/16	R-31
3X3	160	168	171	3-1/8	15	15-1/8	7-1/2	7-9/16	9-1/2	7-5/8	8-25/32	7-1/16	30	1-1/2	5-11/16	8	1	7-1/2	10	2-1/2	5-13/16	7-1/2	R-31
4X3	216	224	227	3-1/8	18	18-1/8	9	9-1/16	11-1/2	7-5/8	8-25/32	7-1/16	30	1-1/2	5-11/16	8	1-1/4	9-1/4	10	2-1/2	5-13/16	7-1/2	R-37
4X4	272	284	293	4-1/16	18	18-1/8	9	9-1/16	11-1/2	9-1/2	10-19/32	8-15/32	48	1-31/32	7-3/32	8	1-1/4	9-1/4	12	2-1/2	6-3/4	9-1/4	R-37
6X4	360	372	381	4-1/16	24	24-1/8	12	12-1/16	15	9-1/2	10-19/32	8-15/32	48	1/31-32	7-3/32	12	1-1/4	12-1/2	12	2-1/2	6-3/4	9-1/4	R-45
6X6	540	564	571	6	24	24-1/8	12	12-1/16	15	11-7/16	12-11/16	10-7/16	48	2-5/32	8-13/16	12	1-1/4	12-1/2	24	3-1/2	8-5/8	11-15/16	R-45
8X6	675	689	706	6	29	29-1/8	14-1/2	14-9/16	18-1/2	11-7/16	12-11/16	10-7/16	48	2-5/32	8-13/16	12	1-1/2	15-1/2	24	3-1/2	8-5/8	11-15/16	R-49
8X8	833	-	925	8	29	29-1/8	14-1/2	14-9/16	18-1/2	14-3/8	-	13-3/8	-	3-1/8	11-1/4	12	1-1/2	15-1/2	30	4-5/8	10-3/32	15-7/8	R-49
10X8	1105	-	1197	8	33	33-1/8	16-1/2	16-9/16	21-1/2	14-3/8	-	13-3/8	-	3-1/8	11-1/4	16	1-1/2	18-1/2	30	4-5/8	10-3/32	15-7/8	R-53
10X10	1387	-	1522	10	33	33-1/8	16-1/2	16-9/16	21-1/2	16-5/8	-	20-1/16	-	3-11/16	12-15/16	16	1-1/2	18-1/2	30	6-1/4	11-7/8	18-3/8	R-53
12X10	1601	-	1936	10	38	38-1/8	19	19-1/16	24	16-5/8	-	20-1/16	-	3-11/16	12-15/16	20	1-1/2	21	30	6-1/4	11-7/8	18-3/8	R-57
12X12	2493	-	2632	12	38	38-1/8	19	19-1/16	24	19-3/8	-	21-1/2	-	4-1/4	15-1/8	20	1-1/2	21	36	6-1/4	14-1/2	20-5/8	R-57

TOP ENTRY BALL VALVE

- One Piece Uni-body Top Entry, Double Block and Bleed
- Full Port, Fire Safe, Blow-out Proof Stem
- Anti-static Device, Cavity Relieving Seats
- NACE MR-01-75, Optional Locking Device
- Designed to ASME B16.34, API 6D

Face to Face	API 6D
End Flange	ASME B16.5
Buttweld	ASME B16.25
Class	ASME CL1500

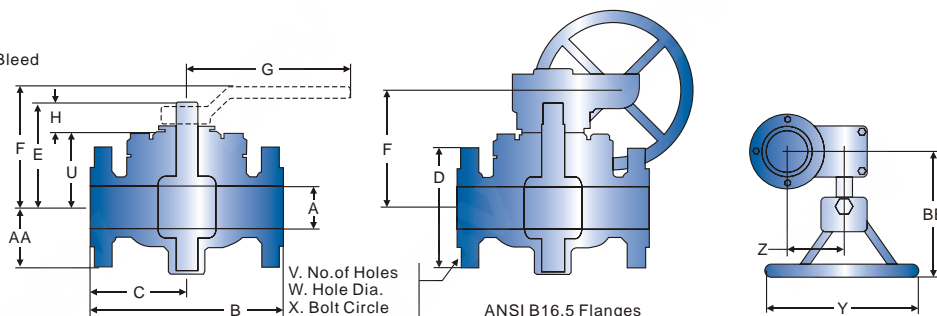

CLASS 1500 DIMENSION

SIZE (in.)	W.T.(lbs.)			A	B		C		D	E	F	G	H	U	V	W	X	Y	Z	AA	BB	Ring Groove RTJ	
	Valve	W/	W/		R	RTJ	R	RTJ			Top of Handle	CL of H/Whl.										Unit: inch	
	Only	H.O.G.O																					
2X2	118	122	124	2-1/16	14-1/2	14-5/8	7-1/4	7-5/16	8-1/2	6-1/2	7-19/32	6	22	1-3/16	4-7/8	8	1	6-1/2	8	1-3/4	5-1/8	7-3/16	R-24
3X2	164	168	172	2-1/16	18-1/2	18-5/8	9-1/4	9-5/16	10-1/2	6-1/2	7-19/32	6	22	1-3/16	4-7/8	8	1-1/4	8	8	1-3/4	5-1/8	7-3/16	R-35
3X3	202	210	213	3-1/8	18-1/2	18-5/8	9-1/4	9-5/19	10-1/2	8-15/16	9-31/32	8-1/4	30	1-5/8	6-7/8	8	1-1/4	8	10	2-1/2	6-1/8	7-1/2	R-35
4X3	299	307	310	3-1/8	21-1/2	21-5/8	10-3/4	10-13/16	12-1/4	8-15/16	9-31/32	8-1/4	30	1-5/8	6-7/8	8	1-3/8	9-1/2	10	2-1/2	6-1/8	7-1/2	R-39
4X4	385	397	398	4-1/16	21-1/2	21-5/8	10-3/4	10-13/16	12-1/4	10-13/32	11-1/2	9-5/16	48	1-31/32	7-15/16	8	1-3/8	9-1/2	12	2-1/2	7	9-1/4	R-39
6X4	475	487	486	4-1/16	27-3/4	28	13-7/8	14	15-1/2	10-13/32	11-1/2	9-5/16	48	1-31/32	7-15/16	12	1-1/2	12-1/2	12	2-1/2	7	9-1/4	R-46
6X6	540	-	605	6	27-3/4	28	13-7/8	14	15-1/2	14-15/16	-	13-5/16	-	3-5/8	11-5/16	12	1-1/2	12-1/2	18	4-5/8	8-3/8	17-5/8	R-46
8X6	675	-	740	6	32-3/4	33-1/8	16-3/8	16-9/16	19	14-15/16	-	13-5/16	-	3-5/8	11-5/16	12	1-3/4	15-1/2	18	4-5/8	8-3/8	17-5/8	R-50
8X8	1488	-	1586	7-5/8	32-3/4	33-1/8	16-3/8	16-9/16	19	14-5/8	-	13-3/8	-	3-3/8	11-1/4	12	1-3/4	15-1/2	18	4-5/8	11-9/16	17-3/4	R-50
10X8	2050	-	2148	7-5/8	39	39-3/8	19-1/2	19-11/16	23	14-5/8	-	13-3/8	-	3-3/8	11-1/4	12	2	19	18	4-5/8	11-9/16	17-3/4	R-54
10X10	2650	-	2775	9-1/2	39	39-3/8	19-1/2	19-11/16	23	20-5/8	-	23-5/16	-	3-11/16	16-15/16	12	2	19	30	6-1/4	12-5/8	20-5/8	R-54
12X10	3242	-	3367	9-1/2	44-1/2	45-1/8	22-1/4	22-9/16	23-1/2	20-5/8	-	23-5/16	-	3-11/16	16-15/16	16	2-1/8	22-1/2	30	6-1/4	12-5/8	20-5/8	R-58
12X12	3613	-	3748	11-3/8	44-1/2	45-1/8	22-1/4	22-9/16	26-1/2	24-1/8	-	21-1/2	-	4-1/4	19-7/8	16	2-1/8	22-1/2	36	6-1/4	14-1/2	20-5/8	R-58

TOP ENTRY BALL VALVE

- One Piece Uni-body Top Entry, Double Block and Bleed
- Full Port, Fire Safe, Blow-out Proof Stem
- Anti-static Device, Cavity Relieving Seats
- NACE MR-01-75, Optional Locking Device
- Designed to ASME B16.34, API 6D

Face to Face	API 6D
End Flange	ASME B16.5
Buttweld	ASME B16.25
Class	ASME CL2500

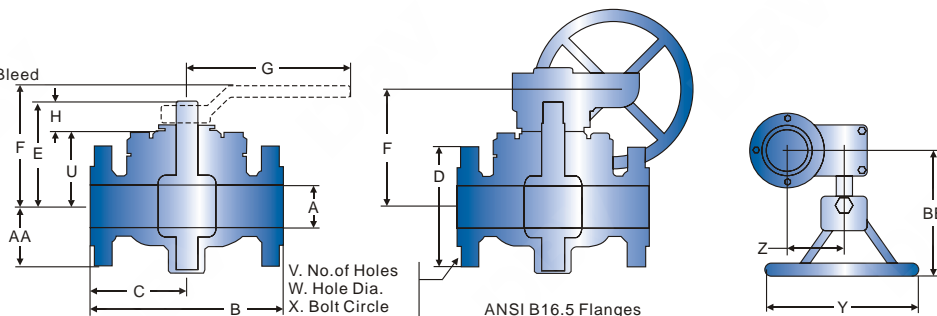

CLASS 2500 DIMENSION

SIZE (in.)	W.T.(lbs.)			A	B		C		D	E	F	G	H	U	V	W	X	Y	Z	AA	BB	Ring Groove RTJ	
	Valve	W/	W/		R	RTJ	R	RTJ			Top of Handle	CL of H/Whl.										Unit: inch	
	Only	H.O.G.O																					
2X2	199	205	207	1-3/4	17-3/4	17-7/8	8-7/8	8-15/16	9-1/4	7-1/2	8-19/32	7	30	1-3/16	5-7/8	8	1-1/8	6-3/4	10	1-3/4	4-1/2	7-1/2	R-26
3X3	341	352	355	2-1/2	22-3/4	23	11-3/8	11-1/2	12	9-13/16	10-37/32	10	48	1-5/8	7-3/4	8	1-3/8	9	12	2-1/2	5-9/16	7-7/8	R-32
4X3	505	516	519	2-1/2	26-1/2	26-7/8	13-1/4	13-7/16	14	9-13/16	10-27/32	10	48	1-5/8	7-3/4	8	1-5/8	10-3/4	12	2-1/2	5-9/19	7-7/8	R-38
4X4	650	-	681	3-1/2	26-1/2	26-7/8	13-1/4	13-7/16	14	11-11/32	-	9-29/32	-	2-11/32	8-27/32	8	1-5/8	10-3/4	24	3-1/2	6-11/16	13-3/8	R-38
6X4	803	-	834	3-1/2	36	36-1/2	18	18-1/4	19	11-11/32	-	9-29/32	-	2-11/32	8-27/32	8	2-1/8	14-1/2	24	3-1/2	6-11/16	13-3/8	R-47
6X6	913	-	994	5-1/4	36	36-1/2	18	18-1/4	19	16-1/32	-	18-9/16	-	3-21/32	12-3/8	8	2-1/8	14-1/2	18	4-5/8	8-7/16	17-5/8	R-47
8X6	1141	-	1222	5-1/4	40-1/4	40-7/8	20-1/8	20-7/16	21-3/4	16-1/32	-	18-9/16	-	3-21/32	12-3/8	12	2-1/8	17-1/4	18	4-5/8	8-7/16	17-5/8	R-51
8X8	2515	-	2640	7-1/8	40-1/4	40-7/8	20-1/8	20-7/16	21-3/4	19-15/16	-	22-5/8	-	3-11/16	16-1/4	12	2-1/8	17-1/4	30	6-1/4	11-1/8	20-5/8	R-51
10X8	3465	-	3590	7-1/8	50	50-7/8	25	25-7/16	26-1/2	19-15/16	-	22-5/8	-	3-11/16	16-1/4	12	2-5/8	21-1/4	30	6-1/4	11-1/8	20-5/8	R-55
10X10	5565	-	5700	8-7/8	50	50-7/8	25	25-7/16	26-1/2	24-13/16	-	26-3/8	-	4-1/4	20-9/16	12	2-5/8	21-1/4	30	6-1/4	13-5/8	20-5/8	R-55
12X10	6808	-	6943	8-7/8	56	56-7/8	28	28-7/16	30	24-13/16	-	26-3/8	-	4-1/4	20-9/16	12	2-7/8	24-3/8	30	6-1/4	13-5/8	20-5/8	R-60
12X12	7587	-	7722	10-1/2	56	56-7/8	28	28-7/16	30	27-1/2	-	19-15/32	-	4-5/16	23-3/16	12	2-7/8	24-1/8	30	6-1/4	14-5/8	20-5/8	R-60

TOP ENTRY BALL VALVE PRESSURE TEMPERATURE AND FLOW DATA

Ball Valve

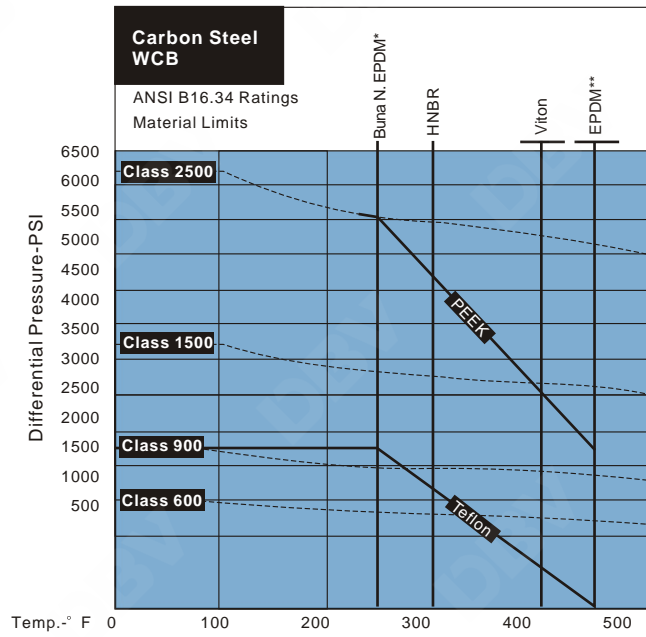
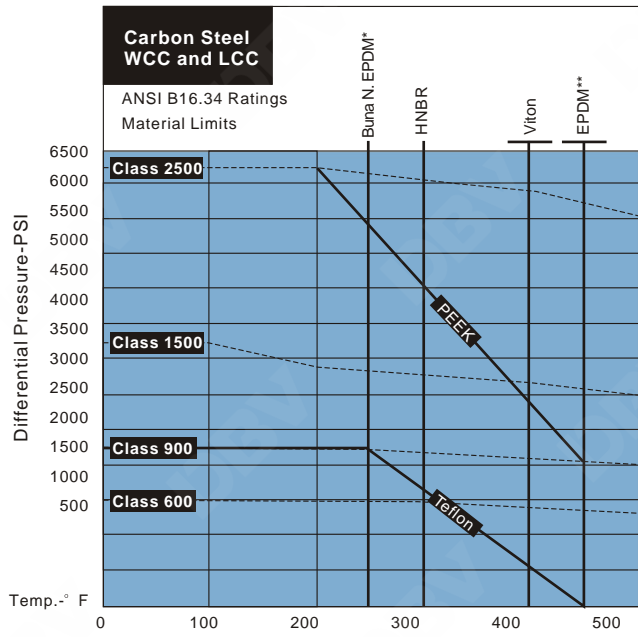

Pressure Temperature Chart Notes: Consult factory for service above 325° F
 *For chemical service. ** For water and steam service only.

LOW TEMPERATURE LIMITS

Body Material	° F	° C	Seat Material	° F	° C
WCC	-20°	-28.9	Teflon	-50°	-45.6
LCC	-50°	-45.6	PEEK	-50°	-45.6
WCB	-20°	-28.9			
CF8M	-50°	-45.6			

Seal Material	° F	° C	Seal Material	° F	° C
Buna N	-30°	-34.4	Viton	+10°	-12.2
Low Temp Buna N	-50°	-45.6	NBR	-40°	-40
Viton	-20°	-28.9	EPDM	-50°	-45.6

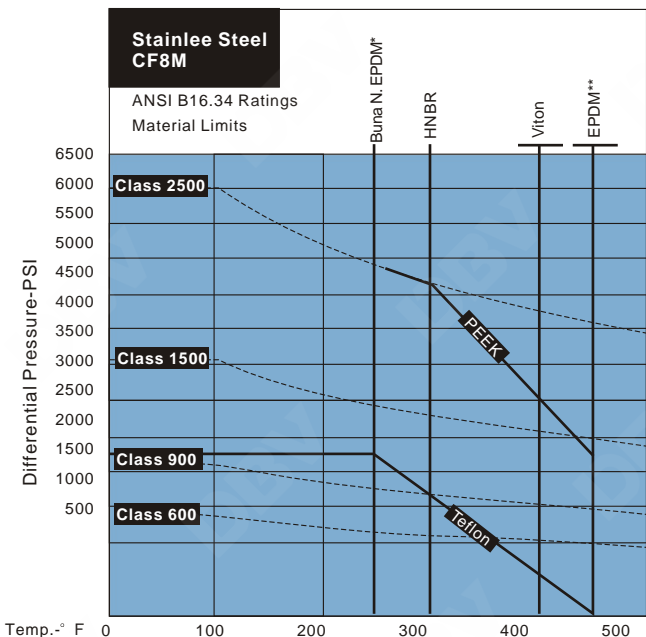

FLOW COEFFICIENT (CV), API 6D & ANSI B16.34

Class	Size (in.)						
	3 R P	4 R P	6 R P	8 R P	10 R P	12 R P	16 R P
600	185	570	890	2235	4605	7525	14.750
900	190	560	800	2150	4500	8000	-
1500	185	570	890	2235	4000	7000	-
2500	170	520	750	2050	3970	6850	-

METHOD OF CALCULATING FLOW

The Flow Coefficient "Cv" of a valve is the flow rate of water (gallons/minute @ 60° F) through a fully opened valve, with a pressure drop of 1 psi across the valve. To find the flow of a liquid or gas through a valve from the Cv, use the following formulas:

Liquid Flow

QL=flow rate of liquid(gal./min.)

ΔP = differential pressure across the valve (psi)

G = Specific gravity of liquid (for water, G=1)

$$Q_L = C_v \sqrt{\frac{\Delta P}{G}}$$

Gas Flow

Qg=flow rate of gas(CFH at STP)

P₂ = outlet pressure (psi)

g = Specific gravity of gas (for air, g=1.000)

$$Q_g = 61 C_v \sqrt{\frac{P_2 \Delta P}{G}} \quad \left\{ \frac{\Delta P}{P_2} < 1.0 \right\}$$

For non-critical flow

VARIANTS

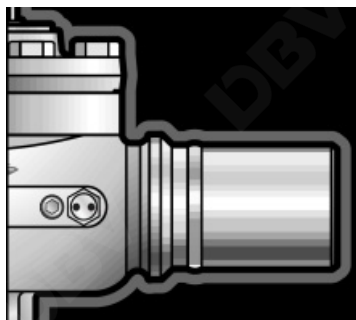

PUPS

Butt Weld vales may be supplied with transition pieces(PUPS) to avoid any risk of seat and seal damage during welding and post weld heat treatment operations. Length of pups and type of pipe and grade to be specified by customer.

ACTUATORS

The bonnet design of DBV Top Entry Ball Valves permits easy adaptation to mount manual, electric, hydraulic, or pneumatic actuators.

METAL SEATED BALL VALVES

DBV Top Entry Metal Seated ball valves have been designed to provide a reliable, efficient and safe method to handle services where high temperatures and/or the presence of solid particles in the fluid make impossible, or not recommended, to use soft seated ball valves.

SUB-SEA OPTIONS: Sub-Sea vales are optionally available upon request

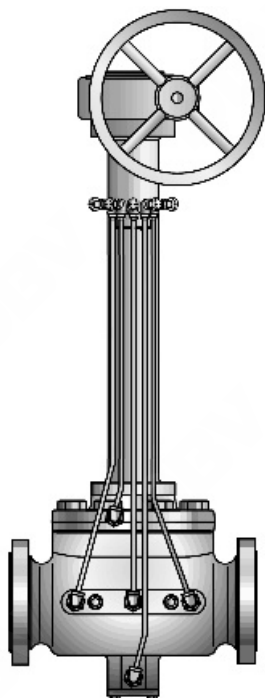

EXTENSIONS

DBV top entry ball valves are available for below ground or buried service with fully operational extensions to meet your specifications. Body Bleed and Sealant Injection functions are maintained along with total valve control by manual or powered actuators. Extension dimensions for Gear Operator or Actuator are given with reference from the valve center line to the center of hand wheel.



INSTALLATION

FLANGE END (RF & RTJ):

Top Entry Ball Valves may be mounted in either vertical or horizontal piping systems. The stem may be positioned vertically to horizontally.

Mating flanges must be correctly aligned. Alignment included bolt bole placement, parallelism, and perpendicularity.

Use proper size gasket or RTJ metal seal. Flange studs or bolting must be correct size and properly tightened.

Properly constructed piping systems do not cause undo stress in valve assemblies. Valves are not intended to make up for insufficient pipe tolerances.

WELD ENDS (WE):

Keep ball in open position prior to installation/welding of DBV Top Entry Weld End Ball Valve.

Place the valve in position by aligning Weld Ends to the pipe.

Prior to welding it is imperative that all welding surfaces be clean from contamination such as dirt, dust and grease which may affect weld performance.

Caution: During the welding process. Valve body temperatures should be monitored around the circumference at a location inline with the sealant injection fittings. The temperatures at this plane should be checked with Temperature Stick or other reliable temperature indicator and not allowed to exceed 300° F. This precaution is necessary to assure that non-metallic seals do not suffer heat damage. Tack weld valve in position and check for proper alignment. Finish weld following proper weld procedure for material grade and condition, and the above Caution.



DBV FULL WELDED BALL VALVE DESIGN FEATURES

SEAMLESS CARBON STEEL BODY

All welded ball valve body is compact and streamline for maximum strength and minimum weight.

STAINLESS STEEL BALL

The stainless steel ball is produced to extremely tight tolerances, and ground to within microns of perfect roundness to assure smooth operations and a tight seal.

OPTIONAL LOCKING DEVICE WITH POSITION INDICATOR

Instantly readable locking device that shows the valve operating position.



STEM BEARINGS

These bearings are produced from an electrically conductive material that provides a safety grounded stem to eliminate static build-up and potential arcing.

SEAT SEALS

The special 25% carbonized PTFE (Teflon) (G-453) seals tightly, yet allows easy, low-torque, quarter-turn operation.

STAINLESS LABELS

Every label is permanently stamped, color coded with traceable serial numbers for each valve.

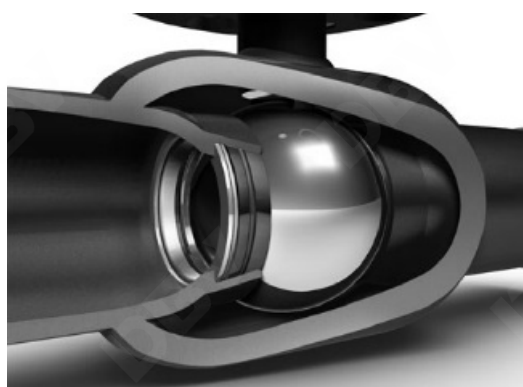

SEAT QUALITY FEATURES

- Do not absorb water, and does not expand
- Chemical resistant
- High friction characteristics
- Good temperature stability
- Tested and approved up to 250°C

DBV FULL WELDED BALL VALVES GENERAL FEATURES

- Uni-body Top Entry
- Double Block and Bleed
- Fire Safe, Anti-static, Stem Blow-out
- Optional Locking Device and Position Indicator
- Size Ranges: 1/2" through 16" (DN15 through DN400)
- Pressure Ratings: ASME Class 150 through Class 900 (PN10 through PN150)
- Standard Materials Ranges: Cast Carbon Steel, Stainless Steel, Alloy Steel etc

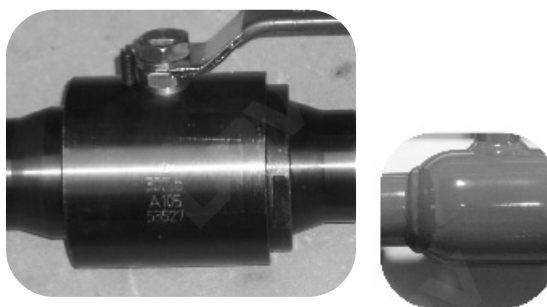

FULL WELDED BALL VALVE - WEIDED END

- One Piece Uni-body, Top Entry, Full Port, Welded Ends
- Floating Ball, Fire Safe, Blow-out Proof Stem
- Anti-static Device, Cavity Relieving Seats
- NACE MR-01-75, Optional Locking Device
- Designed to EN12516, DIN3357-1

Face to Face	EN558-1/DIN 3202
End Flange	EN1092/DIN 2542
Buttweld	EN12627
Class	PN25/PN40

DN125-250

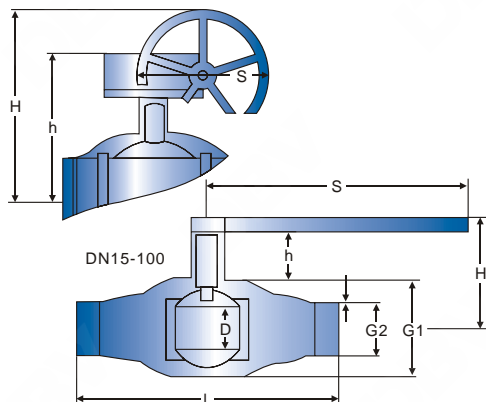

PN25/PN40 DIMENSION

SIZE (DN)	PN	L	D	G1	G2	H	h	t	S
Unit: mm									
15	40	230	15	42.4	26.9	82	38	2.3	120
20	40	230	20	48.3	33.7	105	36	2.6	120
25	40	230	25	60.3	42.4	95	38	2.6	130
32	40	260	32	76.1	48.3	125	49	2.6	160
40	40	260	40	88.9	60.3	135	49	2.9	180
50	40	300	50	108	76.1	118	53	2.9	300
65	25	300	65	127	88.9	141	65	3.2	300
80	25	325	80	159	114.3	188	82	3.6	400
100	25	325	100	193.7	139.7	208	78	4	400
125	25	350	125	219.1	168.3	400	230	4.5	320
150	25	400	150	275	219.1	450	330	4.5	350
200	25	530	200	357	273	525	400	5	350
250	25	550	250	427	325	595	450	5.6	400

FULL WELDED BALL VALVE - FLANGED END

- One Piece Uni-body, Top Entry, Full Port, Flanged Ends
- Floating Ball, Fire Safe, Blow-out Proof Stem
- Anti-static Device, Cavity Relieving Seats
- NACE MR-01-75, Optional Locking Device
- Designed to EN12516, DIN3357-1

Face to Face	EN558-1/DIN 3202
End Flange	EN1092/DIN 2542
Buttweld	EN12627
Class	PN16/PN25/PN40

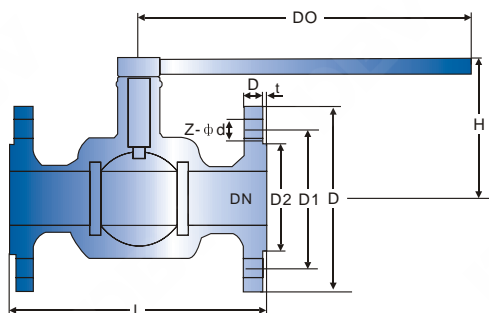

PN16 DIMENSION

SIZE (DN)	L	D	D1	D2	H	b-f	Z-φ d	Do
Unit: mm								
15	130	95	65	45	60	14-2	4-14	108
20	140	105	75	55	64	14-2	4-14	120
25	150	115	85	65	90	16-2	4-14	165
32	165	135	100	78	105	16-2	4-18	180
40	180	145	110	85	150	16-3	4-18	240
50	200	160	125	100	190	16-3	4-18	240
65	220	180	145	120	195	18-3	4-18	320
80	250	195	160	135	215	20-3	8-18	350
100	280	215	180	155	250	20-3	8-18	400
125	320	245	210	185	280	22-3	8-18	500
150	360	280	240	210	320	24-3	8-23	600
200	400	335	295	265	370	26-3	12-23	800

PN25 DIMENSION

SIZE (DN)	L	D	D1	D2	H	b-f	Z-φ d	Do
Unit: mm								
40	180	145	110	85	160	18-3	4-18	240
50	200	160	125	100	205	20-3	4-18	270
65	220	180	145	120	215	22-3	8-18	350
80	250	195	160	135	230	22-3	8-18	400
100	280	230	190	160	270	24-3	8-23	500
125	320	270	220	188	300	28-3	8-25	600
150	360	300	250	218	340	30-3	8-25	900
200	400	360	310	278	400	34-3	12-25	1100

PN40 DIMENSION

SIZE (DN)	L	D	D1	D2	H	b-f	Z-φ d	Do
Unit: mm								
15	130	95	65	45	60	16-2	4-14	40
20	140	105	75	55	65	16-2	4-14	50
25	150	115	85	65	90	18-2	4-14	58
32	180	135	100	78	105	18-3	4-18	66
40	200	145	110	85	170	18-3	4-18	76
50	220	160	125	100	230	20-3	4-18	88
65	250	180	145	120	250	22-3	8-18	110
80	280	195	160	135	250	22-3	8-18	121
100	320	230	190	160	295	24-3	8-23	150
125	400	270	220	188	330	28-3	8-25	176
150	400	300	250	218	375	30-3	8-25	204
200	550	375	320	282	440	38-3	12-30	260

FULL WELDED BALL VALVE WEIDED END WITH STEM EXTENSION

- One Piece Uni-body, Top Entry, Reduced Bore, Welded Ends
- Long Stem, Floating Ball, FireSafe, Blow-out Proof Stem
- Anti-static Device, Cavity Relieving Seats
- NACE MR-01-75, Optional Locking Device
- Designed to EN12516, DIN3357-1

Face to Face	EN558-1/DIN 3202
End Flange	EN1092/DIN 2542
Buttweld	EN12627
Class	PN25/PN40

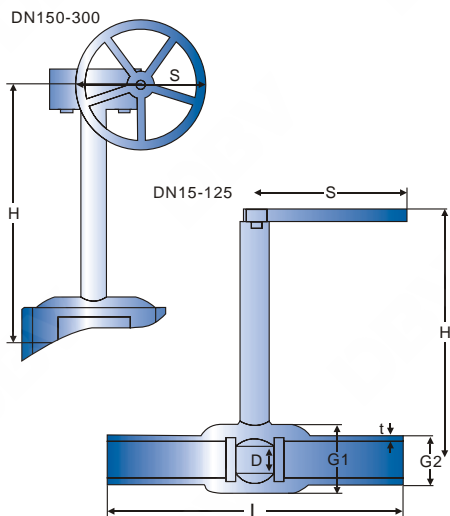

PN25/PN40 DIMENSION

SIZE (DN)	PN	L	D	G1	G2	Hmax	t	S	Unit: mm
15	40	230	10	33.7	21.3	3000	2	120	
20	40	230	15	42.4	26.9	3000	2.3	120	
25	40	230	20	48.3	33.7	3000	2.6	120	
32	40	260	25	60.3	42.4	3000	2.6	130	
40	40	260	32	76.1	48.3	3000	2.6	160	
50	40	300	40	88.9	60.3	3000	2.9	180	
65	25	300	50	108	76.1	3000	2.9	300	
80	25	300	65	127	88.9	3000	3.2	300	
100	25	325	80	159	114.3	3000	3.6	400	
125	25	325	100	193.7	139.7	3000	4	400	
150	25	350	125	219.1	168.3	3000	4.5	320	
200	25	400	150	275	219.1	3000	4.5	350	
250	25	530	200	357	273	3000	5	350	
300	25	550	250	427	325	3000	5.6	400	

FULL WELDED BALL VALVE - WEIDED END

- One Piece Uni-body, Top Entry, Reduced Bore, Welded Ends
- Floating Ball, FireSafe, Blow-out Proof Stem
- Anti-static Device, Cavity Relieving Seats
- NACE MR-01-75, Optional Locking Device
- Designed to EN12516, DIN3357-1

Face to Face	EN558-1/DIN 3202
End Flange	EN1092/DIN 2542
Buttweld	EN12627
Class	PN25/PN40

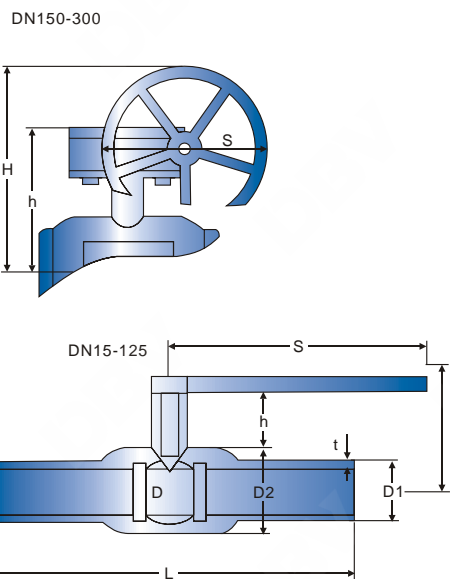

PN25/PN40 DIMENSION

SIZE (DN)	PN	L	D	D1	D2	h	H	S	t	Kv	Unit: mm
15	40	230	10	21.3	33.7	38	80	120	2.0	8	
20	40	230	15	26.9	42.4	38	82	120	2.3	14	
25	40	230	20	33.7	48.3	36	105	120	2.6	25	
32	40	260	25	42.4	60.3	38	95	130	2.6	41	
40	40	260	32	48.3	76.1	49	125	160	2.6	65	
50	40	300	40	60.3	88.9	49	135	180	2.9	108	
65	25	300	51	76.1	108.0	53	118	300	2.9	180	
80	25	300	66	88.9	127.0	65	141	300	3.2	290	
100	25	325	81.5	114.3	159.0	82	188	400	3.6	470	
125	25	325	102	139.7	193.7	78	203	400	4.0	880	
150	25	350	125	168.3	219.1	280	400	320	4.5	1150	
200	25	400	152	219.1	275.0	330	450	350	4.5	1750	
250	25	530	203	273.0	357.0	400	525	350	5.0	3200	
300	25	550	254	325	427.0	450	595	400	5.6	4600	

FULL WELDED BALL VALVE - FLANGED END

- One Piece Uni-body, Top Entry, Reduced Bore, Flanged Ends
- Floating Ball, Fire Safe, Blow-out Proof Stem
- Anti-static Device, Cavity Relieving Seats
- NACE MR-01-75, Optional Locking Device
- Designed to EN12516, DIN3357-1

Face to Face	EN558-1/DIN 3202
End Flange	EN1092/DIN 2542
Buttweld	EN12627
Class	PN25/PN40

DN150-300

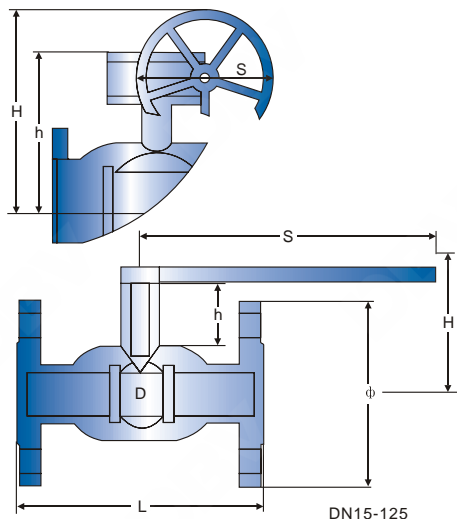

PN25/PN40 DIMENSION

SIZE (DN)	PN (body)	PN (FLG)	L	D	φ	φ1	d	Holes h	H	S	Unit: mm
15	40	40	130	10	95	65	14	4	40	80	120
20	40	40	150	15	105	75	14	4	40	82	120
25	40	40	160	20	115	85	14	4	45	105	120
32	40	40	180	25	140	100	18	4	38	95	130
40	40	40	200	32	150	110	18	4	44	125	160
50	40	40	230	40	165	125	18	4	49	135	180
65	25	16	270	51	180	145	18	4	53	118	300
80	25	16	280	66	200	160	18	8	65	141	300
100	25	16	300	81.5	220	180	18	8	82	188	400
125	25	16	325	102	250	210	18	8	78	203	400
150	25	16	350	125	285	240	22	8	280	400	320
200	25	16	400	152	340	295	22	12	330	450	350
250	25	16	500	203	405	355	26	12	400	525	350
300	25	16	500	254	480	410	26	12	450	595	400

FULL WELDED BALL VALVE WEIDED END WITH STEM EXTENSION

- One Piece Uni-body, Top Entry, Reduced Bore, Welded Ends
- Long Stem, Floating Ball, Fire Safe, Blow-out Proof Stem
- Anti-static Device, Cavity Relieving Seats
- NACE MR-01-75, Optional Locking Device
- Designed to EN12516, DIN3357-1

Face to Face	EN558-1/DIN 3202
End Flange	EN1092/DIN 2542
Buttweld	EN12627
Class	PN25/PN40

DN125-250

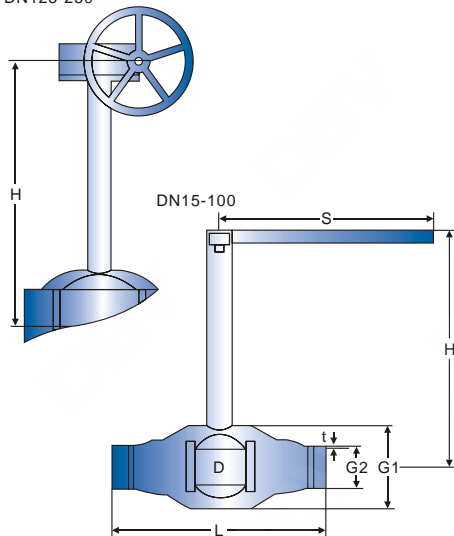

PN25/PN40 DIMENSION

SIZE (DN)	PN	L	D	G1	G2	Hmax	t	s	Unit: mm
15	40	230	15	42.4	26.9	3000	2.3	120	
20	40	230	20	48.3	33.7	3000	2.6	120	
25	40	260	25	60.3	42.4	3000	2.6	130	
32	40	260	32	76.1	48.3	3000	2.6	160	
40	40	300	40	88.9	60.3	3000	2.9	180	
50	40	300	50	108	76.1	3000	2.9	300	
65	25	300	65	127	88.9	3000	3.2	300	
80	25	325	90	159	114.3	3000	3.6	400	
100	25	325	100	193.7	139.7	3000	4	400	
125	25	350	125	219.1	168.3	3000	4.5	320	
150	25	400	150	275	219.1	3000	4.5	350	
200	25	530	200	357	273	3000	5	350	
250	25	550	250	427	325	3000	5.6	400	

FULL WELDED BALL VALVE - FLANGED END

- One Piece Uni-body, Top Entry, Reduced Bore, Flanged Ends
- Floating Ball, Fire Safe, Blow-out Proof Stem
- Anti-static Device, Cavity Relieving Seats
- NACE MR-01-75, Optional Locking Device
- Designed to EN12516, DIN3357-1

Face to Face	EN558-1/DIN 3202
End Flange	EN1092/DIN 2542
Buttweld	EN12627
Class	PN25/PN40

DN 125-250

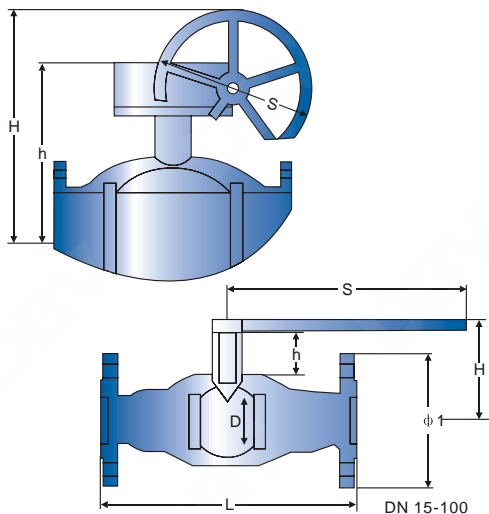

PN25/PN40 DIMENSION

SIZE (DN)	PN (body)	PN (FLG)	L	D	φ 1	φ 2	d	Holes	H	S
15	40	40	245	15	95	65	14	4	40	120
20	40	40	245	20	105	75	14	4	45	120
25	40	40	275	25	115	85	14	4	38	130
32	40	40	275	32	140	100	18	4	44	160
40	40	40	320	40	150	110	18	4	49	180
50	25	40	320	50	165	125	18	4	53	300
65	25	16	325	65	180	145	18	4	65	300
80	25	16	350	80	200	160	18	8	82	400
100	25	16	350	100	220	180	18	8	78	400
125	25	16	375	125	250	210	18	8	280	320
150	25	16	515	150	285	240	22	8	330	350
200	25	16	560	200	340	295	22	12	400	350
250	25	16	595	250	405	355	26	12	450	400

Unit: mm

FULL WELDED BALL VALVE FLANGED END WITH STEM EXTENSION

- One Piece Uni-body, Top Entry, Reduced Bore, Flanged Ends
- Floating Ball, Fire Safe, Blow-out Proof Stem
- Anti-static Device, Cavity Relieving Seats
- NACE MR-01-75, Optional Locking Device
- Designed to EN12516, DIN3357-1

Face to Face	EN558-1/DIN 3202
End Flange	EN1092/DIN 2542
Buttweld	EN12627
Class	PN25/PN40

DN 126-260

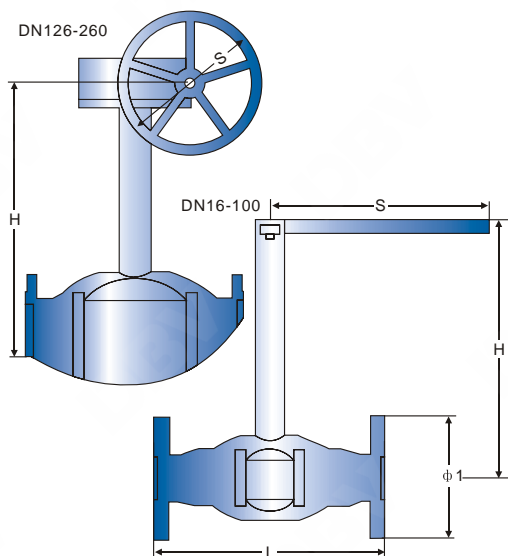

PN25/PN40 DIMENSION

DN	PN (body)	PN (FLG)	L	D	φ 1	φ 2	d	Holes	Hmax	S
15	40	40	245	15	85	65	14	4	3000	120
20	40	40	245	20	105	75	14	4	3000	120
25	40	40	275	25	115	85	14	4	3000	130
32	40	40	275	32	140	100	18	4	3000	160
40	40	40	320	40	150	110	18	4	3000	180
50	40	16	320	50	165	125	18	4	3000	300
65	25	16	325	65	185	145	18	4	3000	300
80	25	16	350	80	200	160	18	8	3000	400
100	25	16	350	100	220	180	18	8	3000	400
125	25	16	375	125	250	210	18	8	3000	320
150	25	16	515	150	285	240	22	8	3000	350
200	25	16	560	200	340	295	22	12	3000	350
250	25	16	595	250	405	355	26	12	3000	400

Unit: mm

DBV SERIES DOUBLE BLOCK AND BLEED BALL VALVE

CHARACTERISTICS

- Double Block and Bleed Valves with double fixed ballshinged on supports, and floating metal or soft seats. Central Needle Vent Valve.
- Pressure Range: from ASME Class 150 to ASME Class 2500.
- Temperature range: from -46°C to 450°C.
- Side Entry Forged Steel Valves.
- On request, Top-Entry design.
- Low pressure loss through the valve.
- Low actuation torque.
- "CE" marking in compliance with PED Directive 97/23/EC.
- Full bore or Reduced bore.
- Different kinds of end connections (RF/RTJ Flanges, Butt Weld, Clamp Connection, Socket Welding).
- Wide availability of materials depending on the specifications (carbon steel, stainless steel or Duplex steel for service in corrosive environments, Chrome-Molybdenum alloy steel for high temperature service, etc.).
- Materials with anti-corrosion properties according to NACE MR 0175.
- On request, seat pocket area overlay, seal area overlay, or completed cladding on wetted surface (welded overlays in Inconel 625, Stainless Steel 316, etc., or Electroless Nickel Plating).
- Suitable for manual (wrench or gear) or motorized actuation (hydraulic, pneumatic, gas-over-oil or electric actuator).

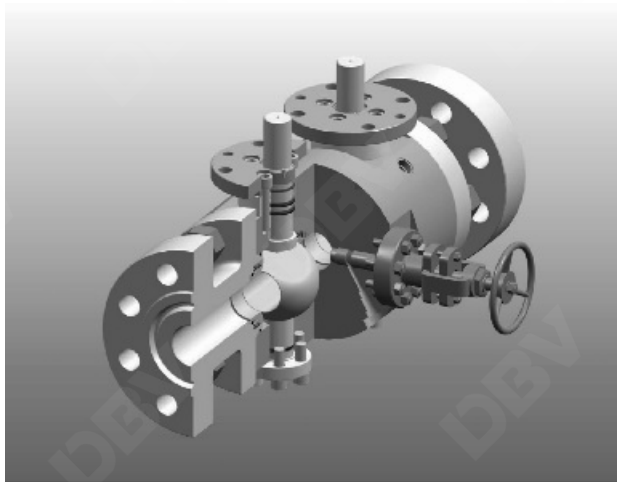

MAIN PARTS

- | | |
|-------------------------------|----------------------------|
| 1. Closure | 19. Seat Spring |
| 2. Body Stud-Nut | 20. Body Stud |
| 3. Seat Ring | 21. Stem O-Ring |
| 4. Adapter Flange | 22. Seat Gasket |
| 5. Body | 23. Seat Back-Up Ring |
| 6. Closure Back-Up Ring | 24. Seat O-Ring |
| 7. Ball | 25. Body Gasket |
| 8. Gland Flange | 26. Closure O-Ring |
| 9. Trunnion | 27. Stem Gasket |
| 10. Gland Flange Gasket | 28. Stem Back-Up Ring |
| 11. Gland Flange Back-Up Ring | 29. Trunnion Back-Up Ring |
| 12. Gland Flange O-Ring | 30. Trunnion O-Ring |
| 13. Trunnion Cap Screw | 31. Gland Flange Cap Screw |
| 14. Stem | 32. Adapter Flange Bushing |
| 15. Gland Flange Cap Screw | 33. Washer |
| 16. Stem Thrust Washer | 34. Cap Screw |
| 17. Trunnion Gasket | 35. Vent Needle Valve |
| 18. Ball Bushing | 36. Stem Key |

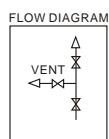
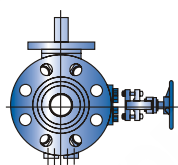
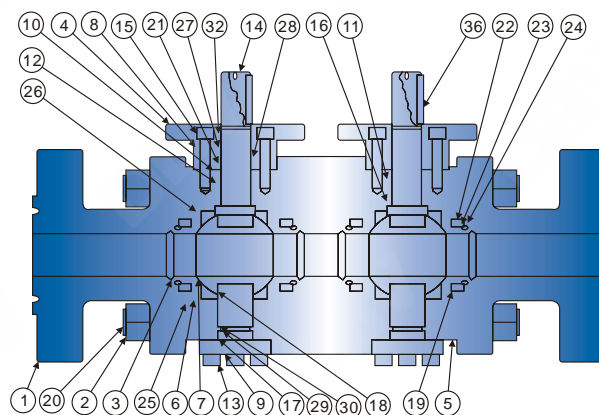
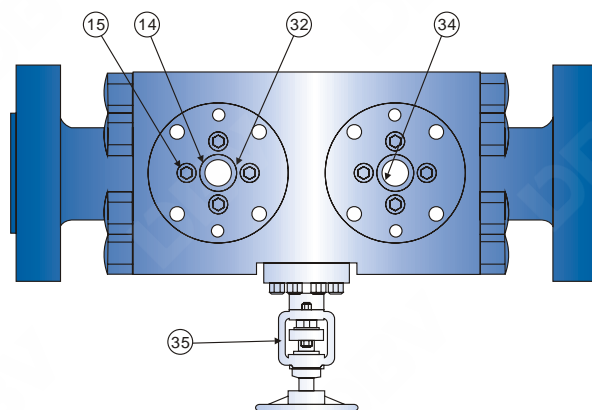

DOUBLE BLOCK & BLEEDBALL VALVE

- Double Block and Bleed, DoubleBall
- Full or Reduced Port, FireSafe, Blow-out ProofStem
- Anti-static Device, Cavity RelievingSeats
- NACE MR-01-75, Optional Locking Device
- Designed to ASME B16.34,API 6D

Face to Face	API 6D
End Flange	ASME B16.5
Buttweld	ASME B16.25
Class	ASME CL150-900

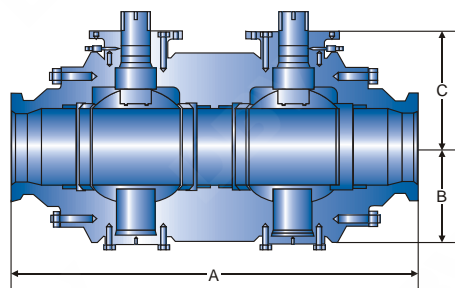

ASME 150

SIZE RF (in.)	A	B	C	W.T (lbs)
	BW	RTJ		
2"	312	378	334	98
3"	355	495	378	127
4"	401	534	422	165
6"	690	800	711	235
8"	800	912	823	239
10"	933	978	956	277
12"	1068	1111	1089	316
14"	1201	1334	1223	341
16"	1334	1467	1356	383
18"	1512	1600	1533	417
20"	1600	1734	1622	454
24"	1867	2000	1890	529

ASME 300

SIZE RF (in.)	A	B	C	W.T (lbs)
	BW	RTJ		
2"	378	378	406	102
3"	495	495	522	148
4"	534	534	562	165
6"	705	800	733	206
8"	879	912	907	239
10"	994	978	1022	277
12"	1134	1111	1162	316
14"	1334	1334	1362	341
16"	1467	1467	1495	383
18"	1600	1600	1628	432
20"	1734	1734	1768	478
24"	2000	2000	2039	578

ASME 600

SIZE RF (in.)	A	B	C	W.T (lbs)
	BW	RTJ		
2"	511	511	516	105
3"	623	623	628	147
4"	756	756	761	165
6"	978	978	984	212
8"	1155	1155	1162	254
10"	1377	1377	1384	303
12"	1467	1467	1472	330
14"	1556	1556	1561	360
16"	1734	1734	1740	401
18"	1911	1911	1916	449
20"	2090	2090	2100	485
24"	2445	2445	2462	584

ASME 900

SIZE RF (in.)	A	B	C	W.T (lbs)
	BW	RTJ		
2"	644	644	649	108
3"	667	667	672	147
4"	800	800	805	165
6"	1068	1068	1073	212
8"	1290	1290	1295	254
10"	1467	1467	1472	303
12"	1689	1689	1694	345
14"	1801	1801	1817	358
16"	1878	1878	1995	407
18"	2133	2133	2156	452
20"	2312	2312	2335	498
24"	2711	2711	2744	597

DOUBLE BLOCK & BLEEDBALL VALVE

- Double Block and Bleed, DoubleBall
- Full or Reduced Port, FireSafe, Blow-out ProofStem
- Anti-static Device, Cavity RelievingSeats
- NACE MR-01-75, Optional Locking Device
- Designed to ASME B16.34,API 6D

Face to Face	API 6D
End Flange	ASME B16.5
Buttweld	ASME B16.25
Class	ASME CL1500/2500

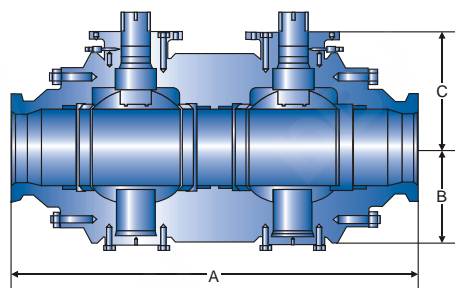

ASME 1500

SIZE RF (in.)	A	B	C	W.T (lbs)
	BW	RTJ		
2"	644	644	649	105
3"	823	823	828	147
4"	956	956	961	165
6"	1234	1234	1244	260
8"	1456	1456	1472	283
10"	1734	1734	1750	349
12"	1978	1978	2006	387
14"	2200	2200	2233	421
16"	2422	2422	2462	474
18"	2690	2690	2728	570
20"	2912	2912	2951	690
24"	3400	3400	3451	733

ASME 2500

SIZE RF (in.)	A	B	C	W.T (lbs)
	BW	RTJ		
2"	789	789	795	144
3"	1012	1012	1022	187
4"	1178	1178	1195	250
6"	1600	1600	1622	280
8"	1789	1789	1817	475
10"	2223	2223	2261	502
12"	2489	2489	2529	514

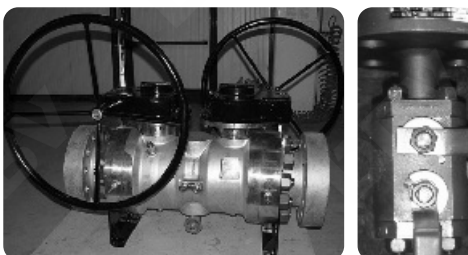

DBV

DBV VALVE CO.,LTD

ONE-STOP CUSTOM VALVE SOLUTION

www.dbv-armaturen.com

Add: No.96 Fanhua East Road,Oubei,Wenzhou,Zhejiang,China.325102

Tel : 086-577-67387721

E-mail : info@dbvvalve.com